

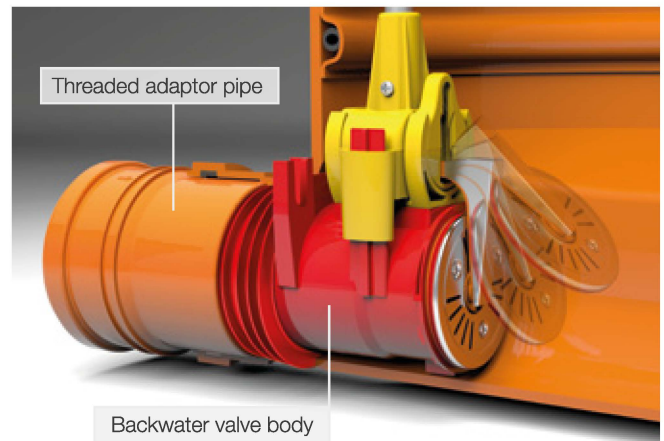

## NOVELTY! Universal backwater valves

### The universal backwater valve for chamber bases of various producers

Its self-operating design allows for easy installation inside most of the chamber bases, sewage and rain water wells available on the market as well as on the ends of sewage and rain water pipes emptying into concrete wells.



- Possibility of removal of the mobile unit above ground without the need of entering the well
- Possibility of extending the rod to several meters
- Chromium-nickel protective guard securing the flap and gasket against damage by rodents and also preventing them from entering the building
- Low cost and simple installation



**UZBKW110**  
**The Universal**  
**ø 110 Backwater Valve**  
**for wells made of plastics**  
**(with removable flap)**  
Weight: 1,51 kg

**UZBKW160**  
**The Universal**  
**ø 160 Backwater Valve**  
**for wells made of plastics**  
**(with removable flap)**  
Weight: 2,5 kg

**UZBKW200**  
**The Universal**  
**ø 200 Backwater Valve**  
**for wells made of plastics**  
**(with removable flap)**  
Weight: 3,6 kg



Sample installation of the valve inside of various manufacturers' chamber bases

# Universal backwater valves for concrete wells

A device which can be installed in pre-existing concrete wells.



Universal backwater valve for concrete wells (with removable flap)

- Installed in the outlet of a sewage pipe in pre-existing concrete wells
- For use in wells with or without manhole openings
- Mobile unit can be removed above ground with the help of the stainless steel rod and handle without entering the well
- When there is a reverse flow, it is stopped by the flap which securely seals to the head of the backwater valve
- Possibility of installation on the cemented outlet of a storm water pipe emptying into rivers or reservoirs
- Chromium-nickel protective guard securing the flap and gasket against damage by rodents and also preventing them from entering the building

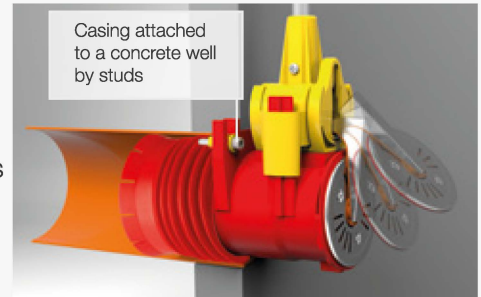

Casing attached to a concrete well by studs



Universal backwater valve for concrete wells (with non-removable flap)



The meticulously designed, finned-seal adheres perfectly to the inner walls of the  $\varnothing$  110 pipes regardless of its thickness – this aspect means that a liquid flowing through does not encounter any obstruction.

Patented by Karmat

For installation in the outlet of a sewage pipe in pre-existing concrete wells

**UZBB110**  
**Universal backwater valve for  $\varnothing$  110 concrete wells**  
 Weight: 0,49 kg

**UZBB160**  
**Universal backwater valve for  $\varnothing$  160 concrete wells**  
 Weight: 1,1 kg

**UZBB200**  
**Universal backwater valve for  $\varnothing$  200 concrete wells**  
 Weight: 1,6 kg

**UZBBW110**  
**Universal backwater valve for  $\varnothing$  110 concrete wells (with removable flap)**  
 Weight: 1,29 kg

**UZBBW160**  
**Universal backwater valve for  $\varnothing$  160 concrete wells (with removable flap)**  
 Weight: 1,9 kg

**UZBBW200**  
**Universal backwater valve for  $\varnothing$  200 concrete wells (with removable flap)**  
 Weight: 2,2 kg



# Backwater valve for flooring installation

**NOVELTY!**

Convenient means of protecting buildings against flooding

In situations where the main sewage pipe runs directly under the floor of the building, the most convenient solution is to use a backwater valve for flooring installation.



- The device enables easy access to the drainage system from the floor level for maintenance purposes
- The backwater valve resists pressures on the lid up to 3 tons
- The lid of the device is securely fastened by chromium-nickel bolts
- Chromium-nickel guard protects the flap and gasket against damage caused by rodents
- Airtight seal prevents bad odors from entering the building - resists internal pressures up to 0,5 bar



PZB 160

**Backwater valve for flooring installation**

Designed for ø 160 pipes

PZB 200

**Backwater valve for flooring installation**

Designed for ø 200 pipes



Chromium-nickel guard protects the flap and gasket against damage caused by rodents

## Installation:

- Backwater valve for flooring installation is designed to be mounted onto a ø160 or ø200 pipe running shallow under the building.
- The backwater valve is installed evenly with the flooring. It is acceptable to install the valve up to 5 mm below this point.
- This device allows easy access to the sewage installation for maintenance purposes from the floor level

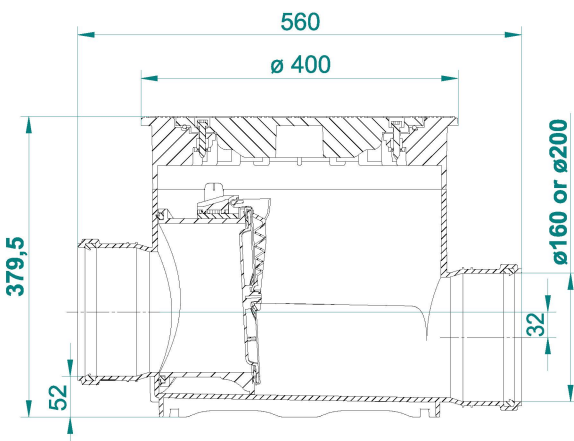
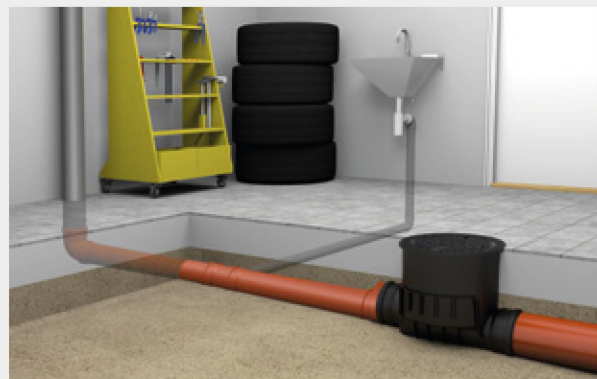

# Wells with backwater valve

Height adjustable

**NOVELTY!**

A new addition to Karmat's offer of single and multi-family housing anti-flooding devices. Well with backwater valve kit is designed to be installed inside or outside of a building.

The installation of the height-adjustable well with a backwater valve at the initial phase of construction allows for its adaptation to the surrounding surfaces.



## Height adjustable wells with backwater valve

- SZB16 - designed for  $\varnothing$  160 pipes
- SZB20 - designed for  $\varnothing$  200 pipes

## Height adjustable wells with backwater valve

- SZB16W - designed for  $\varnothing$  160 pipes
- SZB20W - designed for  $\varnothing$  200 pipes



The airtight cover prevents unpleasant odours from entering the room. The top cover, equipped with a seal, allows for convenient access to the backwater valve mechanism and the piping itself.

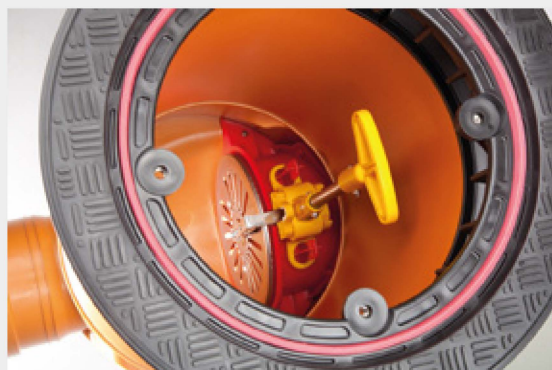

# The chamber base with a backwater valve

Chamber bases with the backwater valve are effective devices for blocking returning waste. Their main advantage is a removable flap valve.

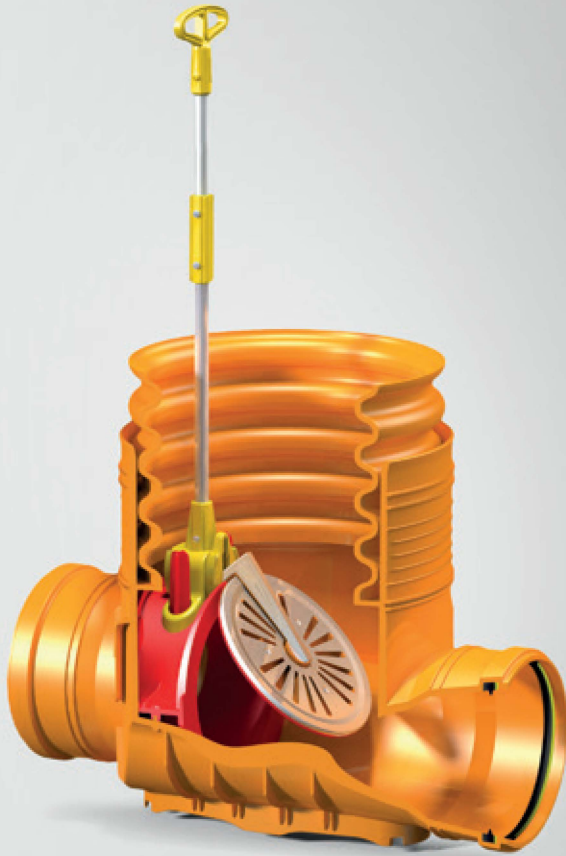

## Advantages

- Effective building protection
- Low cost and simple installation
- Possibility of removal of the flap valve without the need for entering the well.
- Maintenance by a specialist is unnecessary
- Resistance to corrosion, negative temperatures and chemicals

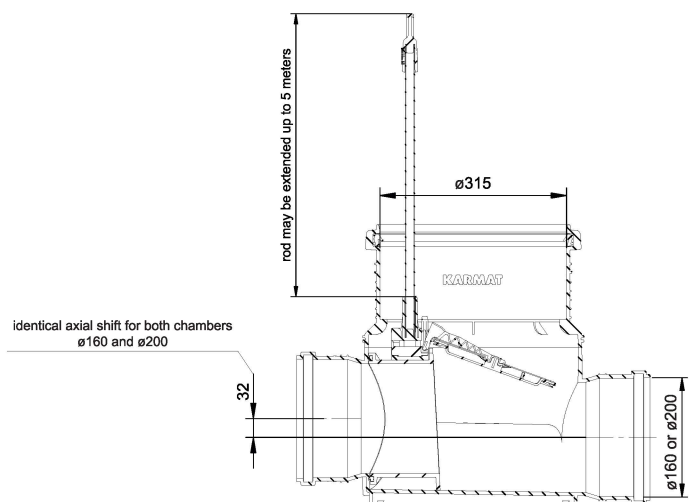
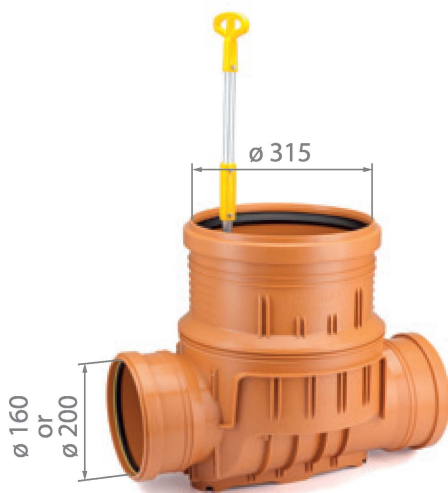

**K31P16ZB**  
dedicated for  $\varnothing 160$  pipes

**K31P20ZB**  
dedicated for  $\varnothing 200$  pipes

**chamber base with a backwater valve  
for solid wall riser pipe  $\varnothing 315$**

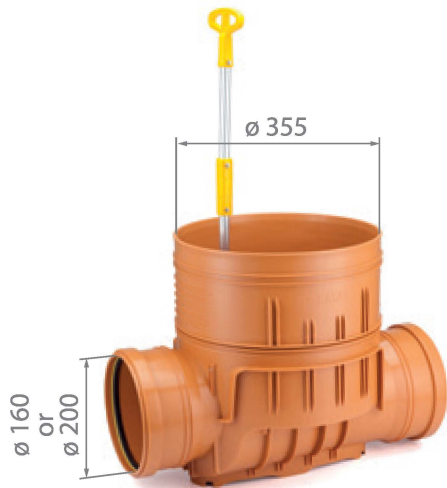

**K35P16ZB**  
dedicated for  $\varnothing$  160 pipes

**K35P20ZB**  
dedicated for  $\varnothing$  200 pipes

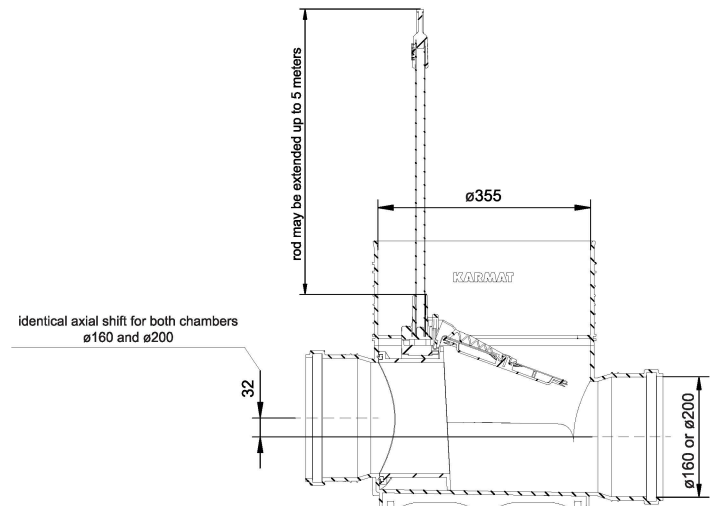

**The chamber base with a backwater valve  
for corrugated riser pipe  $\varnothing$  315  
(external diameter of riser pipe  $\varnothing$  355)**



**K40P16ZB**  
dedicated for  $\varnothing$  160 pipes

**K40P20ZB**  
dedicated for  $\varnothing$  200 pipes

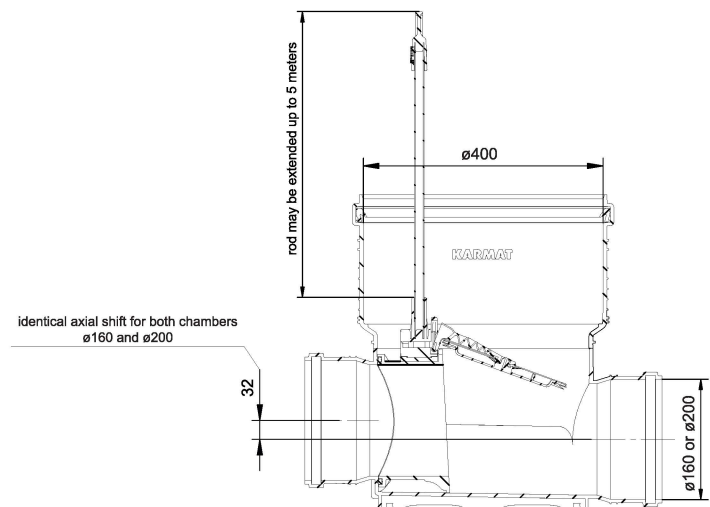

**The chamber base with a backwater valve  
for solid wall riser pipe  $\varnothing$  400**



**PRZ70**  
Extension Rod

ALL NECESSARY SEALS COME INCLUDED IN THE SET

Products meet the EN13564 and EN13598 standards and are marked with the CE symbol

## Application

The chamber base with a backwater valve is designed for use in sanitary sewage or rainwater systems. The recommended location for installation is a sewer pipe between the building and the main sewer network. The chamber base also serves as an inspection well protecting the building from flooding.

Watertight covers are recommended for use with chamber bases equipped with the backwater valves. They effectively block the returning sewage from spilling over the ground surface. They also prevent bad odours from escaping.



Chamber base with a backwater valve

## Principle of operation

The phenomenon of sewage backflow causes regression of water into the building and flooding of low-lying areas. It can be caused by intense rainfall, thaw or flood.

During normal operation of the chamber with a backwater valve sewage flows freely, lifting the loosely hanging flap of the device. When there is a reverse flow, it is stopped by the flap which securely seals to the head of the backwater valve. This process takes place completely automatically.

The flap is fixed to the chromium nickel extension rod with a handle on the end. This enables easy removal of the unit from the well for the purpose of inspection and maintenance. After the inspection we easily put the mobile unit back in its place in the well by means of the rod.



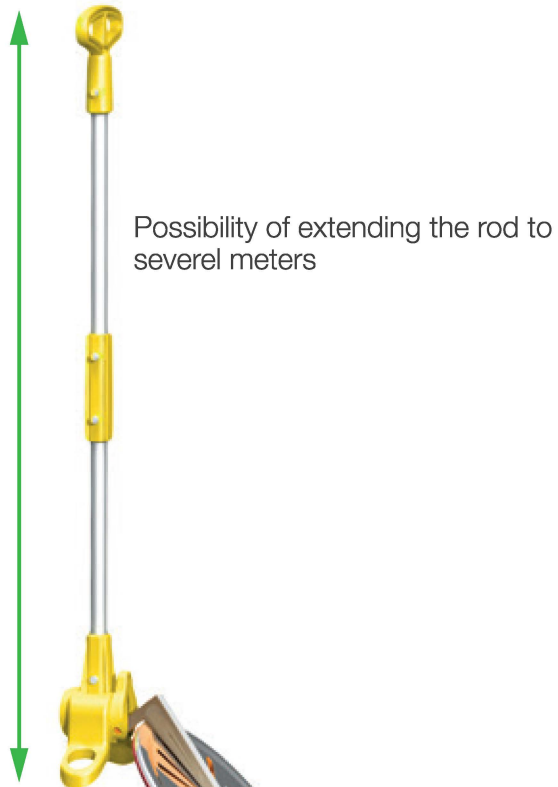

The flap is permanently fixed to the chromium-nickel extension rod

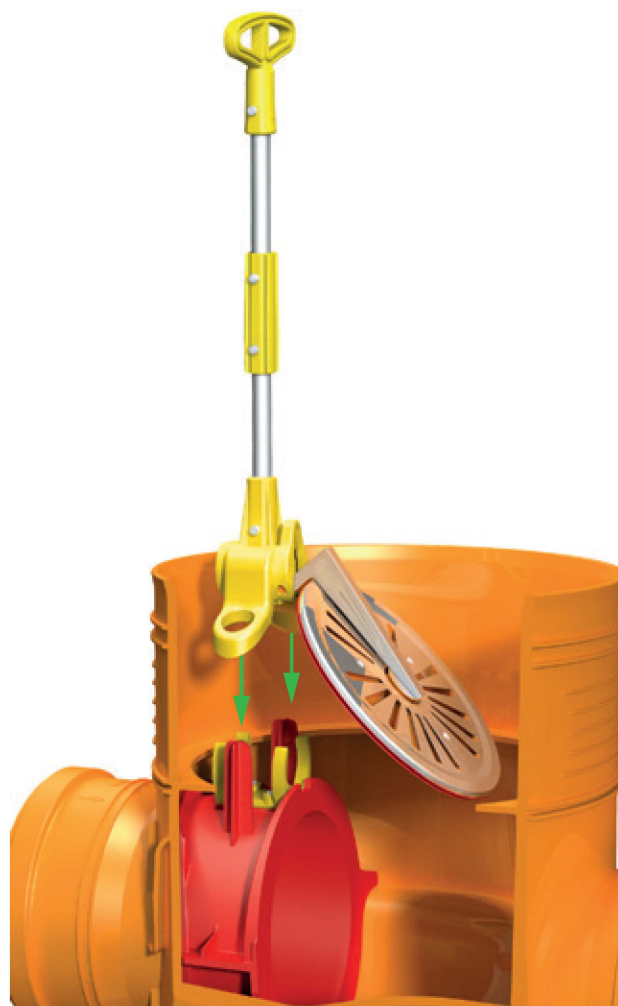
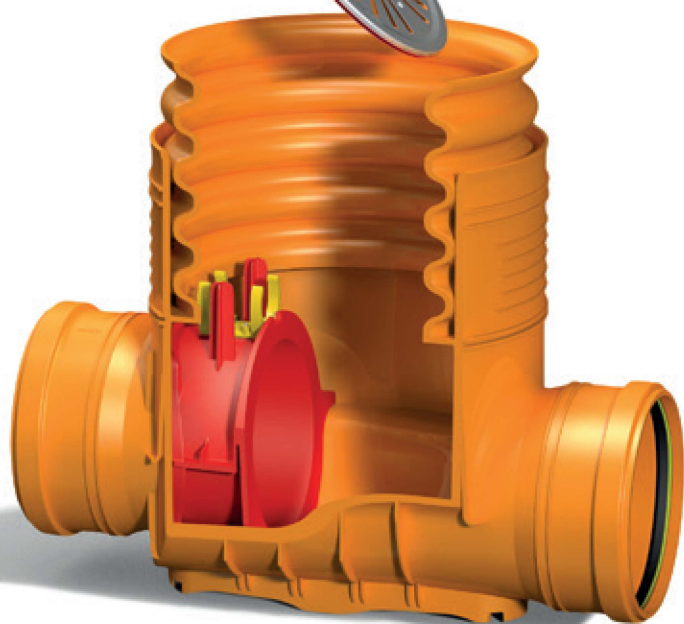

Easy to use snap-on system

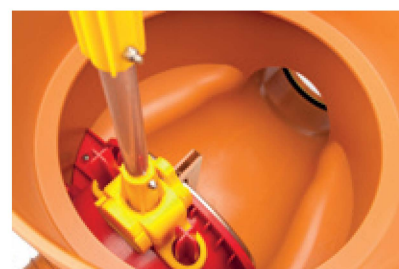
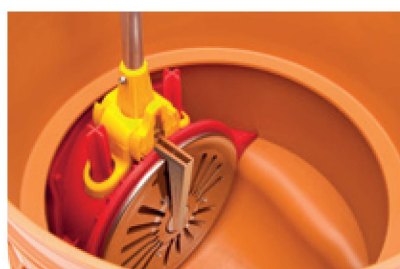
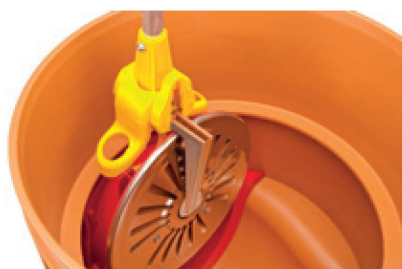

# Collection bases - with 4 sockets



**K31Z16**  
dedicated for  $\varnothing$  160 pipes

**K31Z20**  
dedicated for  $\varnothing$  200 pipes

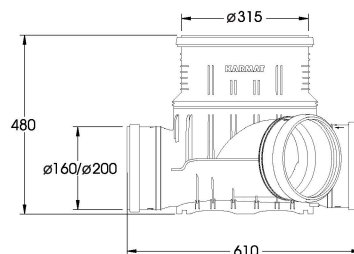

**Collection base – 3 inlet,  
for solid-wall riser pipe  $\varnothing$  315**



**K35Z16**  
dedicated for  $\varnothing$  160 pipes

**K35Z20**  
dedicated for  $\varnothing$  200 pipes

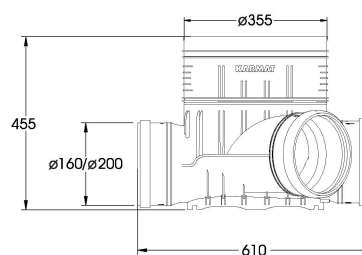

**Collection base – 3 inlet, for  
corrugated riser pipe  $\varnothing$  315  
(external diameter  $\varnothing$  355)**



**K40Z16**  
dedicated for  $\varnothing$  160 pipes

**K40Z20**  
dedicated for  $\varnothing$  200 pipes

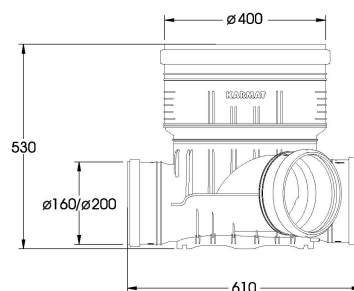

**Collection base – 3 inlet,  
for solid-wall riser pipe  $\varnothing$  400**

# Collection base - plain outlet



K31Z16B  
dedicated for  $\varnothing$  160 pipes

K31Z20B  
dedicated for  $\varnothing$  200 pipes

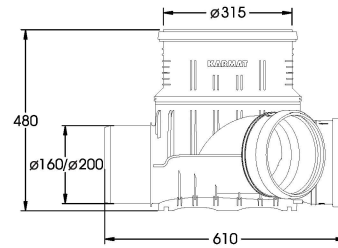

**Collection base – 3 inlet,  
for solid-wall riser pipe  $\varnothing$  315**



K35Z16B  
dedicated for  $\varnothing$  160 pipes

K35Z20B  
dedicated for  $\varnothing$  200 pipes

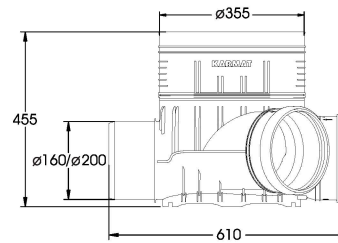

**Collection base – 3 inlet,  
for corrugated riser pipe  $\varnothing$  315  
(external diameter  $\varnothing$  355)**



K40Z16B  
dedicated for  $\varnothing$  160 pipes

K40Z20B  
dedicated for  $\varnothing$  200 pipes

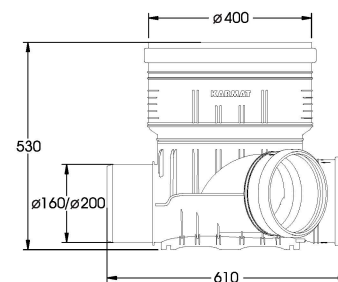

**Collection base – 3 inlet,  
for solid-wall riser pipe  $\varnothing$  400**

# Straight Chamber Bases



**K31P16**

dedicated for  $\varnothing$  160 pipes

**K31P20**

dedicated for  $\varnothing$  200 pipes

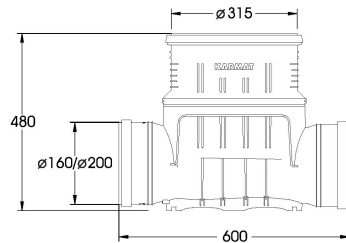

**Straight, for solid wall riser pipe  $\varnothing$  315**



**K35P16**

dedicated for  $\varnothing$  160 pipes

**K35P20**

dedicated for  $\varnothing$  200 pipes

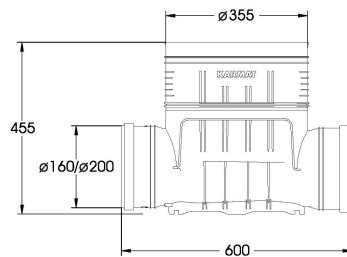

**Straight, for corrugated riser pipe  $\varnothing$  315 (external diameter  $\varnothing$  355)**



**K40P16**

dedicated for  $\varnothing$  160 pipes

**K40P20**

dedicated for  $\varnothing$  200 pipes

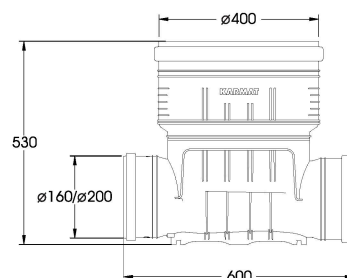

**Straight, for solid wall riser pipe  $\varnothing$  400**

## Karmat Chamber Bases

have smooth internal surfaces suitably profiled to allow for undisturbed free-flow of water which prevents the build-up of sediments inside the pipes, this also simplifies annual flushing of the wells.

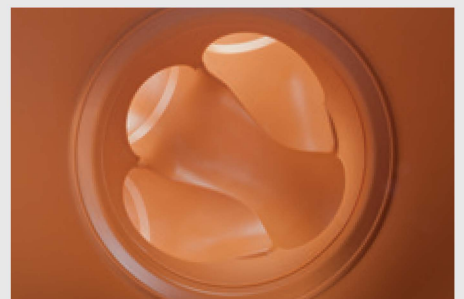
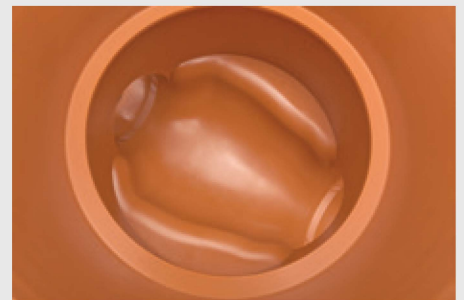

Chamber bases are made of a material resistant to chemicals found in waste-water.

Accordingly designed, ribbed exterior of the chamber base ensures suitable stiffness and resistance against soil weight pressure.

# Backwater valves

Karmat Backwater Valves (non-return valves) effectively secure any rooms located in the lower floors against flooding caused by back flow of storm water and sewage. Back flow may be caused by intense rains, thaw or floods. Use of anti-flooding devices for rooms located on the lower floors is required by obligatory building code regulations.

- made of a durable and high quality polipropylene
- resistant to corrosion, negative temperatures and chemicals
- simple and effective closure mechanism
- easy to install
- self operating without the need of external power
- effective rodent protection
- inhibits unpleasant smells from reentering



Maximum operating temperature 95°C

Maximum operating pressure 0.5 bar

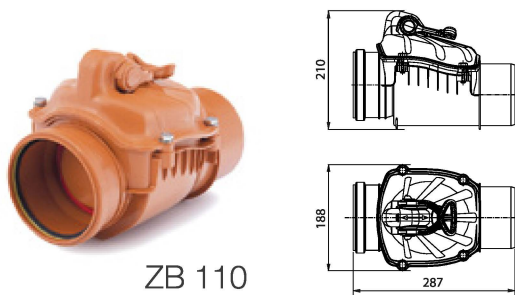

ZB 110

**Backwater valve ø 110**

Installed onto sewage pipes ø 110, weight: 0,94 kg

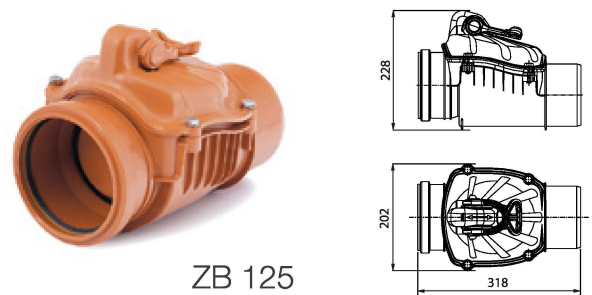

ZB 125

**Backwater valve ø 125**

Installed onto sewage pipes ø 125, weight: 1,24 kg

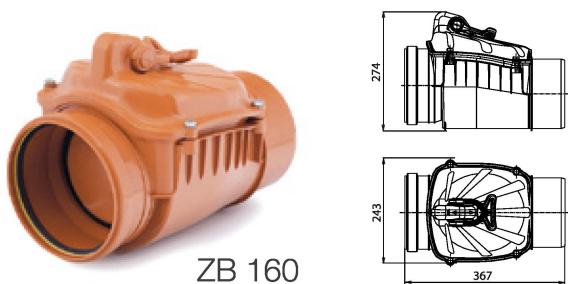

ZB 160

**Backwater valve ø 160**

Installed onto sewage pipes ø 160, weight: 2,03 kg

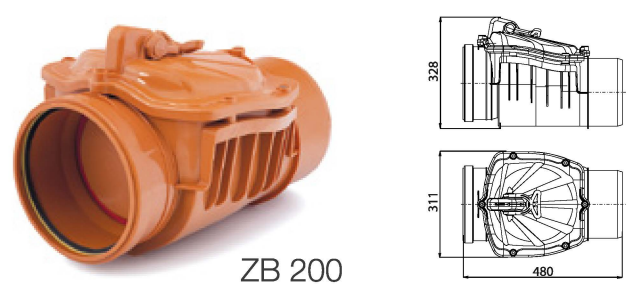

ZB 200

**Backwater valve ø 200**

Installed onto sewage pipes ø 200, weight: 3,60 kg

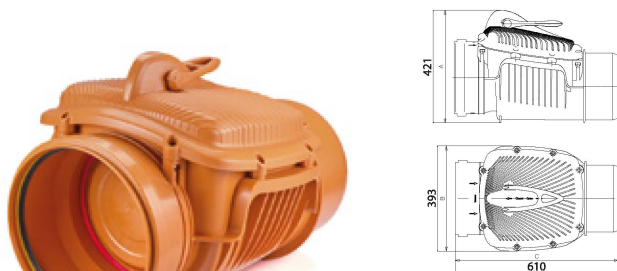

ZB 250

**NOVELTY!**

**Backwater valve ø 250**

Installed onto sewage pipes ø 250, weight: 7,8 kg



ZB 315

**NOVELTY!**

**Backwater valve ø 315**

Installed onto sewage pipes ø 315, weight: 13,3 kg

In compliance with EN13564 standards and marked with the CE symbol

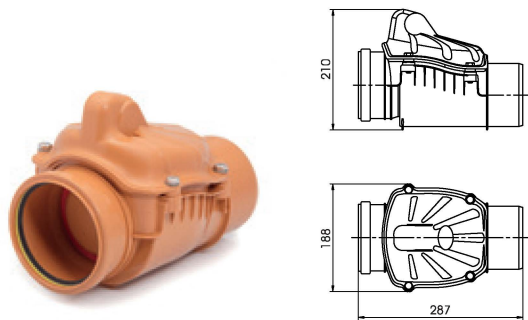

ZBTPO 110

**Anti-flood valve without lever ø 110**  
 Installed onto sewage pipes ø 110, weight: 0,85 kg

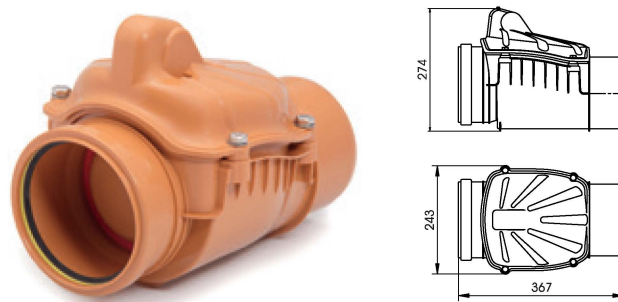

ZBTPO 160

**Anti-flood valve without lever ø 160**  
 Installed onto sewage pipes ø 160, weight: 1,80 kg

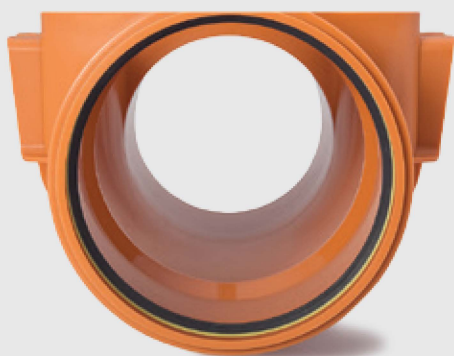

The device's interior with its smooth surface properly profiled, protects against sediment collection and grants complete and undisturbed sewage flow.



Gaskets have been manufactured from a rubber of high resistance to atmospheric influences and to aging.

## Effective protection against rodents

KARMAT backwater valve prevents against rats and other rodents entering building interiors through the sewage, sanitary and rainwater drainage systems. It also protects against unpleasant smells in case of longer breaks in system use.

The shape of the protective guard has been designed to protect the gasket against damage by rodents and sliding during sewage flow.



The flap guard, as well as all assembly elements (screws, nuts, washers) are made from corrosion resistant chromium nickel.



A full-open position allows for 100% sewage flow

KARMAT backwater valves are equipped with a manual closure lever. Changing of the lever from OPEN position (A) to CLOSED position (B) causes a complete arrest of sewage backflow. It enables protection against unpleasant smells in case of longer breaks in household sanitary system use.

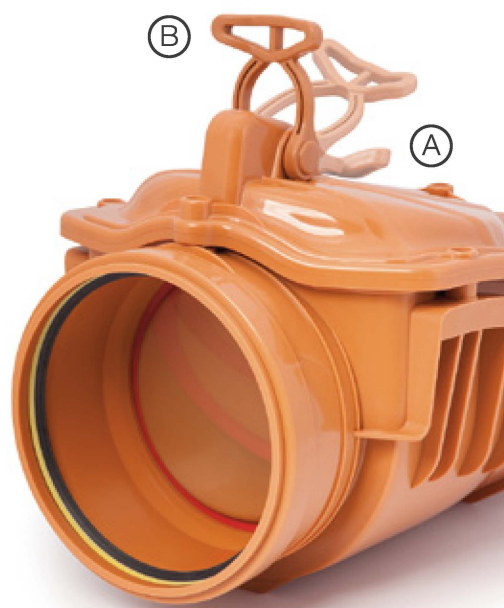
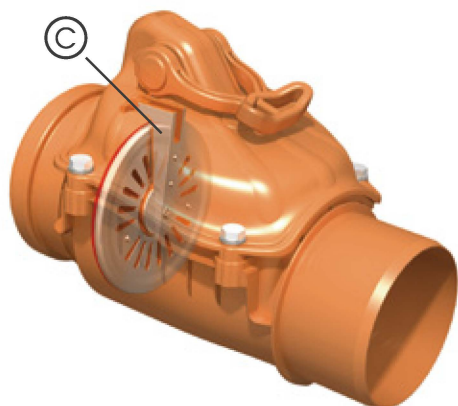

Additional chromium-nickel arm guard (C) - available upon request.

## Example of installation

Backwater valves are installed in horizontal sewage pipes before they exit a building or sewage drain outside the building before its connection to an external network. They are also installed in inspection chambers made of concrete or plastic.



Karmat backwater valve  $\varnothing$  160  
in a  $\varnothing$  600 collection well

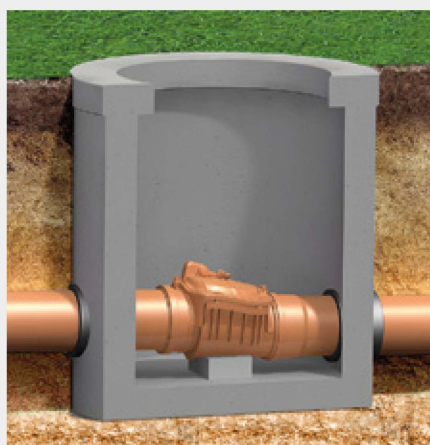

Karmat backwater valve  $\varnothing$  200  
in a  $\varnothing$  1000 concrete well

# Backwater valve for vertical assembly

Karmat offers a unique product on the market - a backwater valve designed for vertical installation

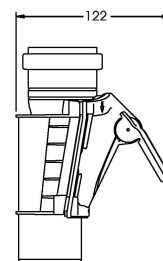
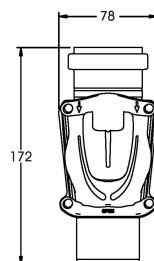

ZB50-P biała

ZB50-P pop

**backwater valve  $\varnothing$  50 for vertical installation**  
Installed onto sewage pipes  $\varnothing$  50, weight: 0,15 kg

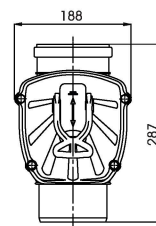
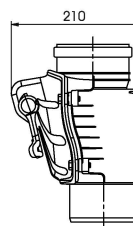

ZB 110 PION

**Backwater valve  $\varnothing$  110 for vertical installation**  
Installed onto sewage pipes  $\varnothing$  110, weight: 0,97 kg

THE POSSIBILITY OF  
MOUNTING ON A VERTICAL  
PIPE MEANS NO NEED  
FOR CONVERSIONS  
AND LOWER COSTS



## Simple control of proper operation



The designed manual closure, allows you to use it also in a vertical position. It also provides the possibility to verify proper valve operation without removing the cover

Backwater valves mounted vertically operate automatically and reliably.

## A backwater valve mounted on a vertical drain pipe

is a comfortable, cheap and often the only way of protecting a building against flooding



automatic shut-off during back flow



# Double flap backwater valve

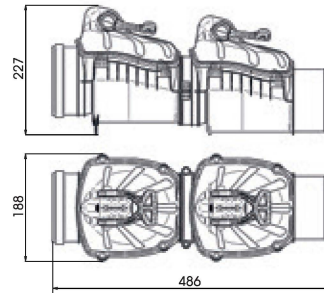

ZB2K 110

**Double flap backwater valve  $\varnothing$  110**

Installed onto sewage pipes  $\varnothing$  110, weight: 1,85 kg

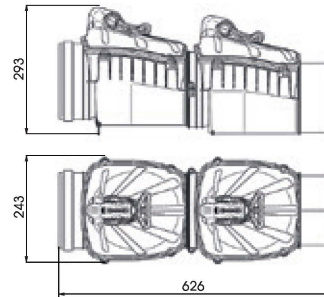

ZB2K 160

**Double flap backwater valve  $\varnothing$  160**

Installed onto sewage pipes  $\varnothing$  160, weight: 3,95 kg

## Double flap backwater valve

Karmat backwater valves are devices in which the flaps are equipped with chromium - nickel protective guards securing the flap and gasket against rats and its sliding during sewage flow. It is a very important feature in places particularly exposed to rodents' attempts to pass through.

Their installation is advisable in regions prone to repetitive backflow of sewage.



# What distinguishes us

- Devices have two independent protective covers which are beneficial during back flow because the pressure affecting the first flap is not immediately transferred to the other.
- Karmat double flap backwater valves are equipped with an innovative chromium-nickel lever guard (C), which constitutes additional security.
- These are the only valves with two flaps equipped with two levers for manual closing available on the market. It enables fast evaluation of proper operation of both flaps. The easy change of both levers from opening position (A) to closing position (B) and back means that both flaps work properly in the valve and it is not necessary to carry out any additional maintenance operations.
- The possibility to check proper operation of both flaps is a great advantage of such a technical solution.

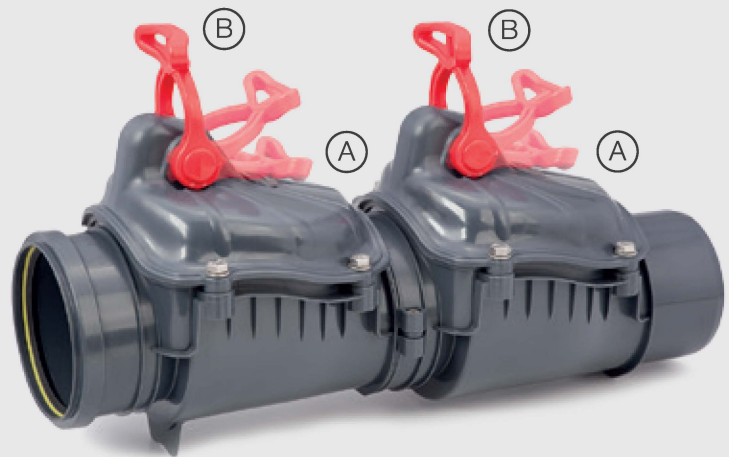

## Original technical solutions

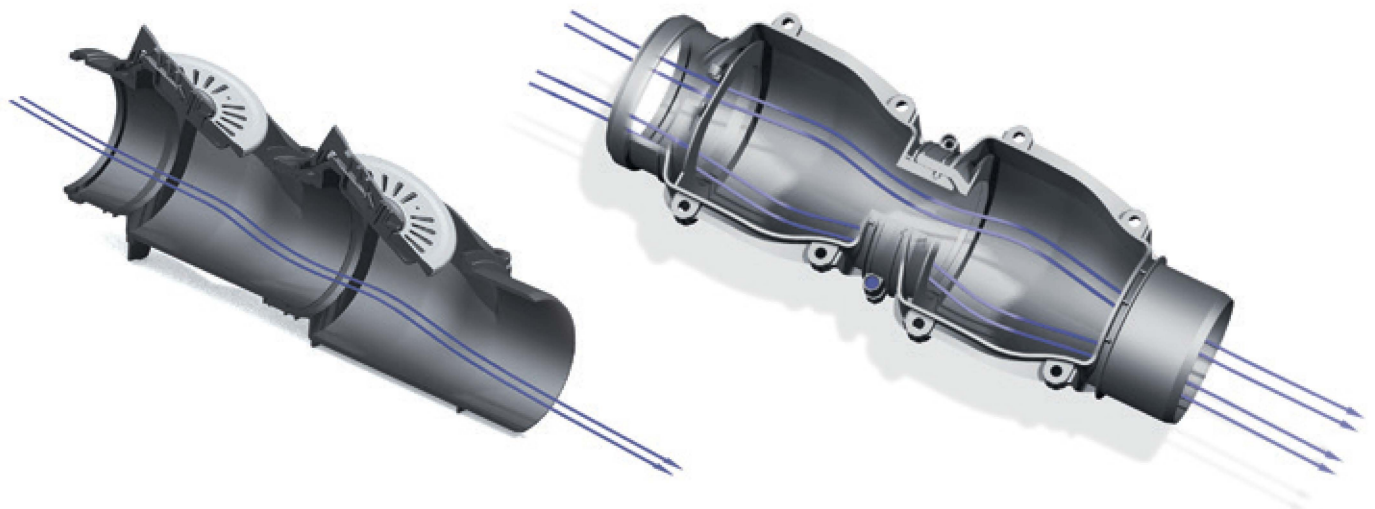

Smooth internal surfaces suitably profiled

Unrestricted sewage flow

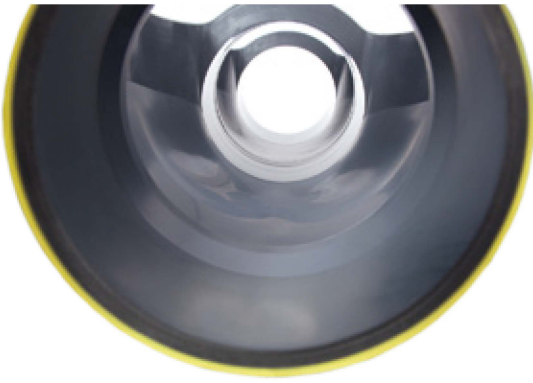

- Double flap backwater valves have smooth internal surfaces suitably profiled which causes its self-cleaning and prevents collection of sediments. This also enables undisturbed sewage flow while maintaining a complete and unnarrowed clearance of pipes in which they are installed.

## Sample installation

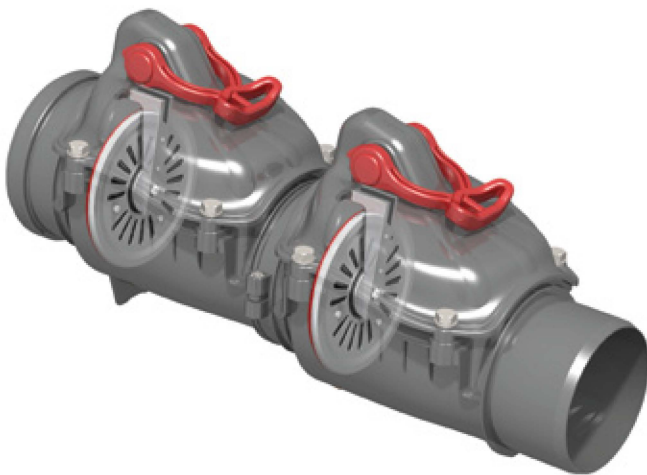

Double flap backwater  $\varnothing$  110



Karmat double flap backwater valve  
 $\varnothing$  110 in a  $\varnothing$  600 collection well

QUALITY  
RELIABILITY  
AESTHETICS

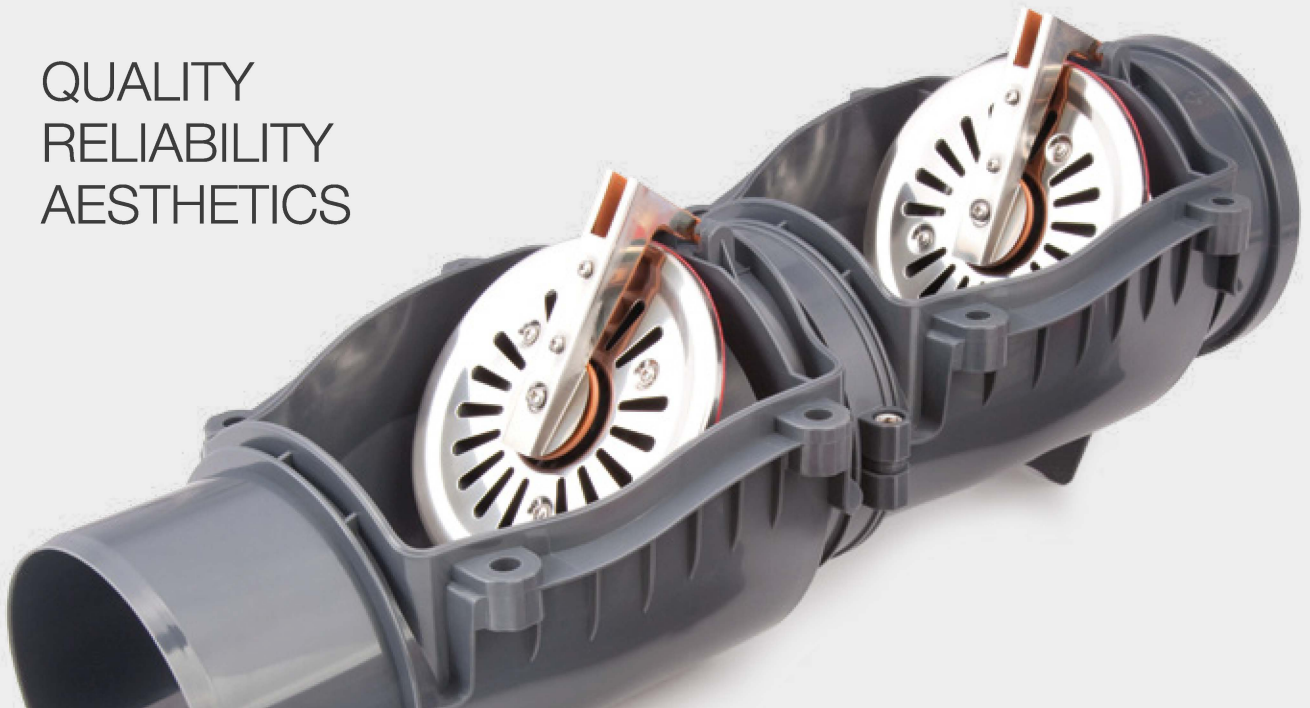

# Flap valves

Flap valves effectively protect plumbing systems from rats entering the buildings.

## KARMAT Flap valves

1. Flap valves and drainage flap valves are made from polypropylene of the highest quality with a supplemented regulator which increases the resistance to sunbeams as well as other atmospheric factors.
2. A market novelty, it is a specially constructed drainage flap valve which protects drainage installations against backward flooding and silting due to increasing water levels above the drainage level. The drainage flap valve is installed directly onto the end of a drainage pipe leading to the drainage ditch or a drainage well.



ZBK 110

### Flap valve ø 110

installed onto sewage pipes ø 110, weight: 0,33 kg



ZBK 160

### Flap valve ø 160

installed onto sewage pipes ø 160, weight: 0,73 kg



ZBK 200

### Flap valve ø 200

installed onto sewage pipes ø 200, weight: 1,16 kg

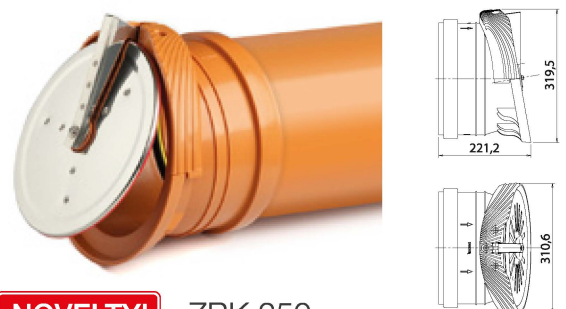

**NOVELTY!**

ZBK 250

### Flap valve ø 250

installed onto sewage pipes ø 250, weight: 2,25 kg



**NOVELTY!**

ZBK 315

### Flap valve ø 315

installed onto sewage pipes ø 315, weight: 3,9 kg



ZBK-DR

### Drainage flap valve with universal coupler

installed onto drainage pipes from ø 72 to ø 100, weight: 0,36 kg

# Reliable and effective connection

A drainage flap valve has a universal connection system consisting of popular Karmat drainage couplers, which enables its installation on drainage pipes or corrugated pipes without holes, from 72 to 100 mm diameter.

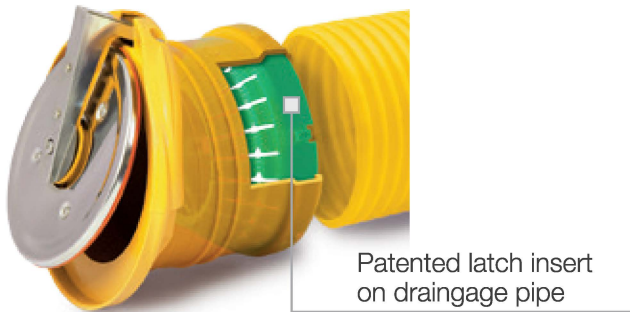
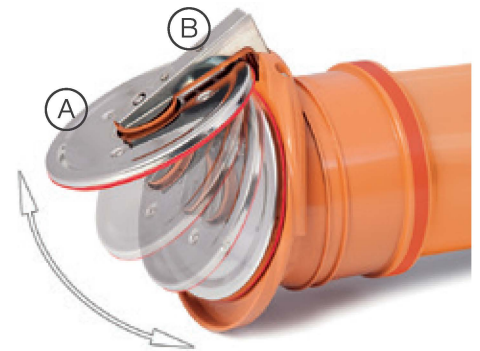

Patented latch insert on drainage pipe

All flap valves are equipped with a chromium-nickel cover (A) protecting the flap and gasket. Additionally a chromium-nickel cover of the lever (B) has been introduced. They protect against rodents, atmospheric and the environmental conditions (eg. river flow).

Example of the assembly of the flap valve and drainage flap valve draining water to a drainage ditch.



Flap valve **ZBK 110, 160 or 200**

concrete

drainage flap valve **ZBK-DR**

granular fill

natural soil

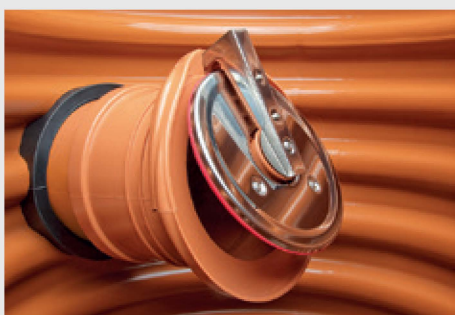

Flap valves are mounted by installers onto the ends of sewage pipes draining into collection wells, septic tanks as well as on drainage pipes draining rain water into ditches or rivers.

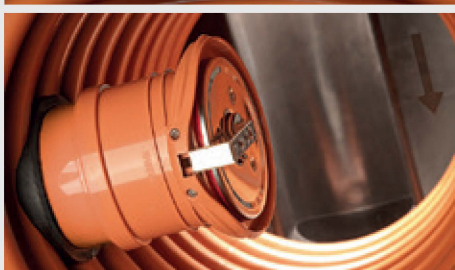

Flap valve  $\varnothing$  110 in a  $\varnothing$  315 collection well

# Backwater valve $\varnothing$ 50

Karmat backwater valve  $\varnothing$  50 is an ideal solution where it is impossible to install a backwater valve protecting the entire building e.g. in an apartment block.



ZB50-A biała    ZB50-A pop    ZB50-A orange

## ZB50 VERSION A

### Non-return valve $\varnothing$ 50

Installed onto sewage pipes  $\varnothing$  50, weight: 0,15 kg

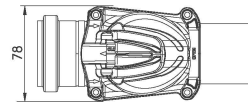
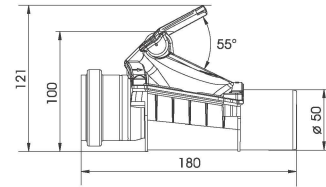

ZB50-B biała    ZB50-B pop

## ZB50 VERSION B

### Non-return valve $\varnothing$ 50

Installed onto sewage pipes  $\varnothing$  50, weight: 0,17 kg

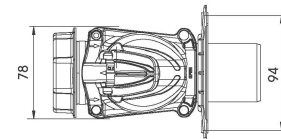
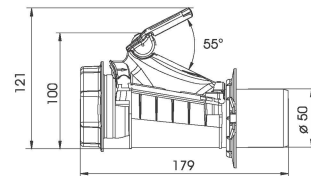

ZB50-C biała    ZB50-C pop

## ZB50 VERSION C

### Non-return valve $\varnothing$ 50

Installed onto sewage pipes  $\varnothing$  50, weight: 0,22 kg

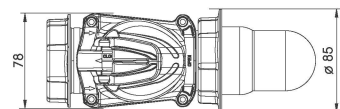
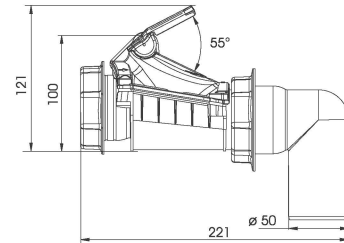

ZB50-P biała    ZB50-P pop

## vertical Backwater valve $\varnothing$ 50

Installed onto sewage pipes  $\varnothing$  50, weight: 0,15 kg

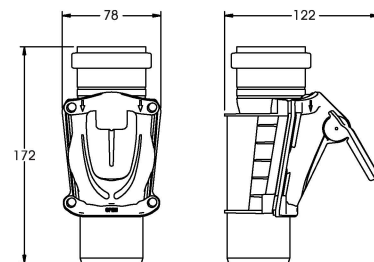

# Sample installation

With the aim to make installation easier, KARMAT produces the  $\varnothing$  50 backwater valve in versions A, B, C as well as in vertical. They are used in all sewage-related systems such as washbasins, sinks, shower bases, dishwashers and washing machines.

## Backwater valves $\varnothing$ 50 VERSION A

The backwater valve  $\varnothing$  50 in version A is fitted in the horizontal course of  $\varnothing$  50 sewage pipework attached to the wall by means of brackets. A backwater valve installed in such a way can protect several facilities at the same time if they are connected to the same sewage system such as a bath or shower base traps.

Version A is a great protective solution in hard-to-reach areas e.x. bath and shower base syphons.

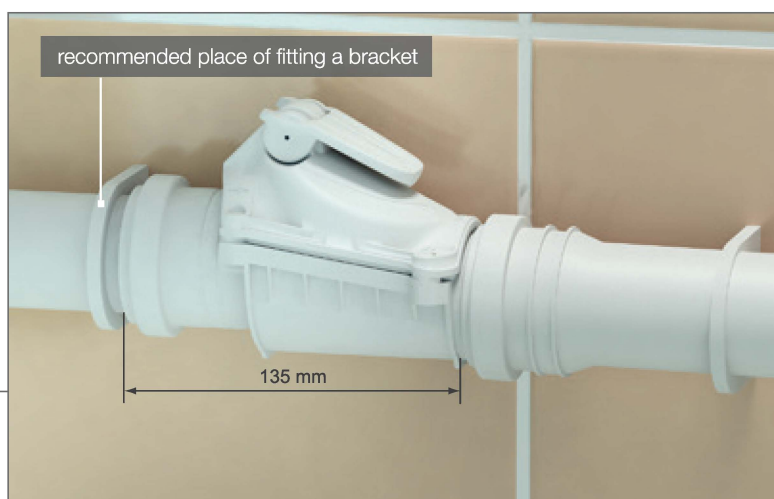

## Backwater valves $\varnothing$ 50 VERSION B

The backwater valve in version B is connected to the  $\varnothing$  50 pipe socket of an existing pipe fitting in the wall. A special aesthetic masking rosette allows the valve to be mounted to the wall by means of two screws. This protects the system from self-detachment in cases of increased pressure in the system caused by sewage backflow. To the device mounted in such way, the trap (e.g. a washbasin) is to be connected by means of a special connector with a screw cap.

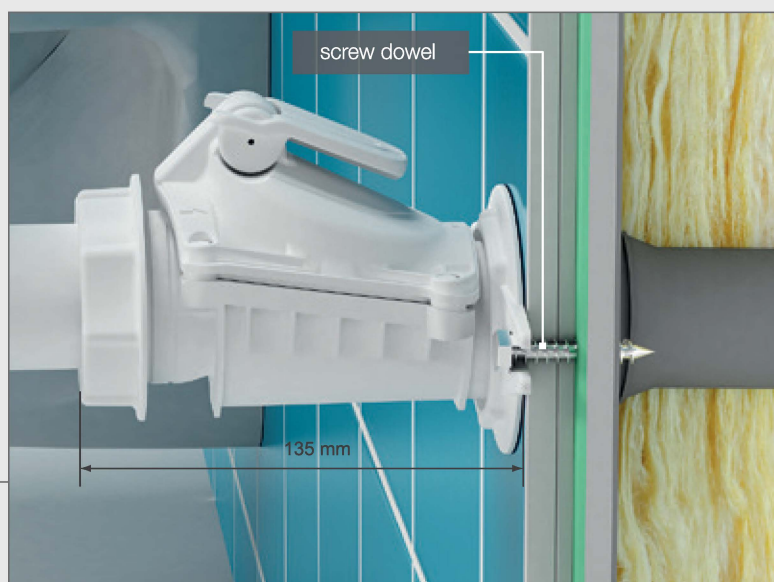

# Backwater valves $\varnothing$ 50 VERSION C

Backwater valve  $\varnothing$  50 in version C is designed for installation in new or altered sewage systems.

It is mounted to the wall by means of a special  $\varnothing$  50 elbow which is to be connected to the valve with a special nut, that also takes the role of a masking rosette at the same time.

The elbow enables to orient the outflow, at any angle, to the left or to the right and protects the system from self-detachment in the case of increased pressure in the sewage system caused by sewage backflow.

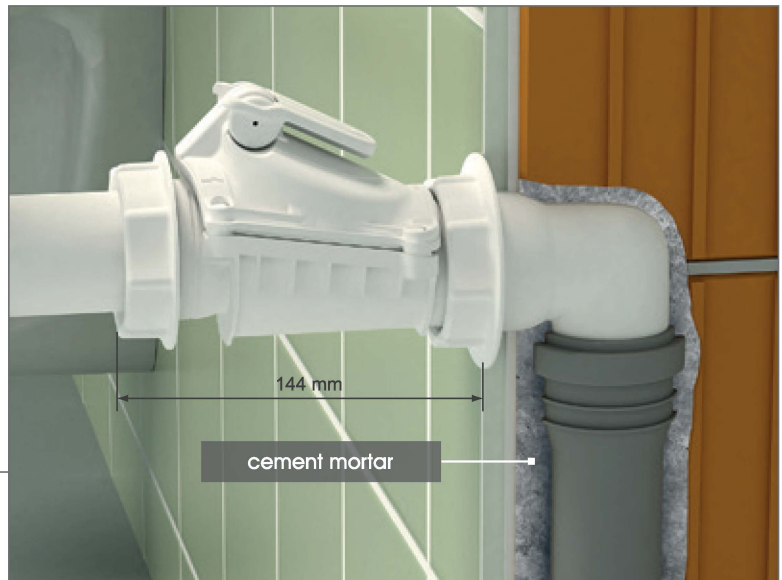

## Method of connecting traps to the valves in version B and C

Trap is easily and tightly connected to the valve by means of a nut and conic gasket.

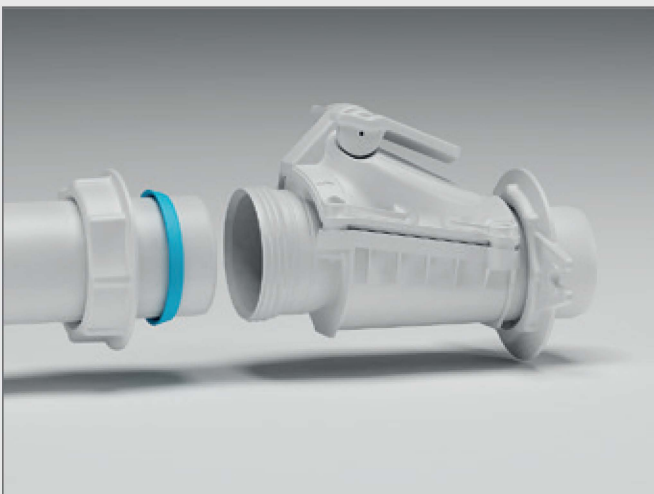

## Proper mounting of the backwater valve in version C

When mounting the elbow to the wall, it is necessary to leave outside 11 to 13,5 mm of screw-thread. Fixing the valve to it, is easy due to a nut and special gasket.



## Comfortable manual closure

## Backwater valve $\varnothing$ 50 version C

All  $\varnothing$  50 backwater valves have a convenient maintenance lever. A small move of the lever blocks the flow quickly and efficiently. This allows to protect premises from unpleasant odours in case of a household sewage system being unused for a longer period of time.



## Efficient protection against rodents



The shape of the chromium-nickel stainless steel guard protects the flap and gasket from damage by rodents and the slipping of the seals during sewage flow.

Compatible with the standard, the safe distance of the bottom of the casing ensures proper operation and allows for the self-cleaning of the valves



Smooth and properly shaped internal surface allows free flow of sewage and makes the accumulation of deposits or the blocking up of the valve impossible.



# Karmat Chamber Covers

- Highest Quality

All Karmat covers are produced with an A15 rating from the highest quality polymers resistant to high and low temperatures.

- Substantially increased resistance to pressure confirmed in tests by an independent laboratory

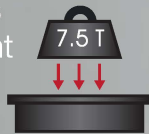

- The used UV stabilizer greatly increases the resistance of the cover against atmospheric factors and preserves their intensive color



- Their varied shape allows for easy selection according to its application. The square shaped covers can be easily encased by cobble stones or the installation near the edge of a pavement.

- All screws and bolts used in the Karmat covers are made of corrosion resistant chromium-nickel



- A special anti-skid pattern was designed on the surface of the cover - the pattern is copyrighted in the Patent Office.



# Standard covers



Strengthened construction of the cover permits for a fivefold resistance to pressure

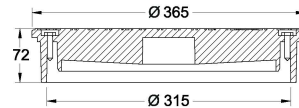

P315

**Standard cover**

For solid wall pipe  $\varnothing$  315

increased resistance to **7,5 tons**

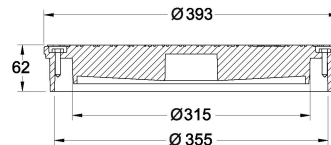

P355

**Standard cover**

For corrugated pipe  $\varnothing$  315 (outside 355 mm)

increased resistance to **7,5 tons**

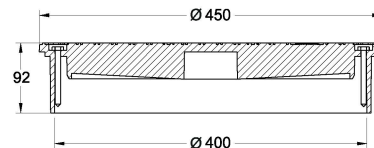

P400

**Standard cover**

For solid wall pipe  $\varnothing$  400 or corrugated pipe  $\varnothing$  400

increased resistance to **7,5 tons**

INCREASED RESISTANCE - CONTAINS UV STABILIZERS

# Watertight covers

Karmat Watertight covers solve the frequent and inconvenient problem of bad odours emanating from the sewer.

They have the ability to move in telescopic fashion to compensate for the movement of the soil during winter months.

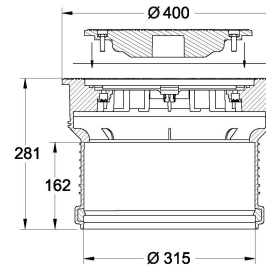

PS315

**Watertight covers**

Full lid for solid wall pipe  $\varnothing$  315

increased resistance to **3 tons**

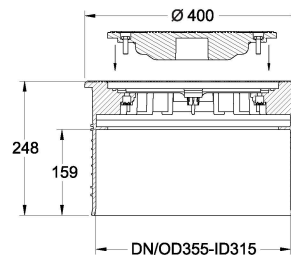

PS355

**Watertight covers**

Full lid for corrugated pipe  $\varnothing$  315 (external diameter 355 mm)

increased resistance to **3 tons**

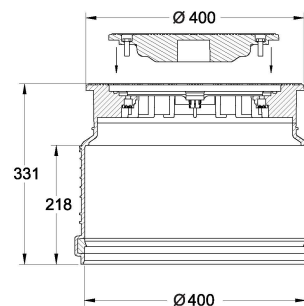

PS400

**Watertight covers**

Full lid for solid wall pipe  $\varnothing$  400

increased resistance to **3 tons**

INCREASED RESISTANCE - CONTAINS UV STABILIZERS

Watertight covers are resistant to pressures up to **0.5 bar**

# Socket covers with stormwater lid

Socket covers with stormwater lid have the possibility to move in telescopic fashion with the ground during winter months.

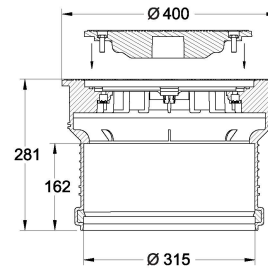

PS315D

Socket covers with stormwater lid  
Slotted lid

For solid wall pipe  $\varnothing$  315

increased resistance to **3 tons**

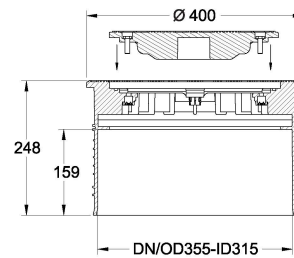

PS355D

Socket covers with stormwater lid  
Slotted lid

For corrugated pipe  $\varnothing$  315 (external diameter riser pipe  $\varnothing$  355 mm)

increased resistance to **3 tons**

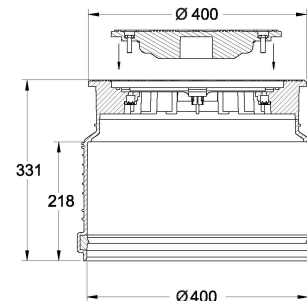

PS400D

Socket covers with stormwater lid  
Slotted lid

For solid wall pipe  $\varnothing$  400

increased resistance to **3 tons**

INCREASED RESISTANCE - CONTAIN UV STABILIZERS

# Telescopic covers

Telescopic covers allow for easy height adjustment and leveling with the ground during installation. In a simple manner they compensate for the surface movement which changes its height in winter conditions.

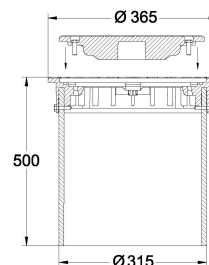

PTO315

**Telescopic cover**

Round telescopic cover with full lid

increased resistance to **3 tons**

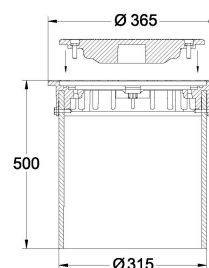

PTO315D

**Telescopic cover**

Round telescopic cover with slotted lid

increased resistance to **3 tons**

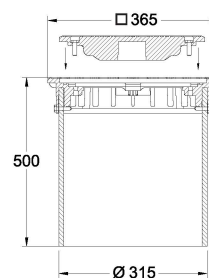

PTK315

**Telescopic cover**

Square telescopic cover with full lid

increased resistance to **3 tons**

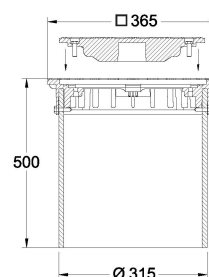

PTK315D

**Telescopic cover**

Square telescopic cover with slotted lid

increased resistance to **3 tons**

INCREASED RESISTANCE - CONTAINS UV STABILIZERS

# Telescopic covers - without telescopic pipe ø 315

Lower transportation costs



DTO315

## Telescopic covers

Round telescopic cover with full lid (without telescopic pipe)

increased resistance to **3 tons**

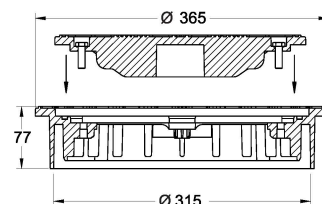

DTO315D

## Telescopic covers

Round telescopic cover with slotted lid (without telescopic pipe)

increased resistance to **3 tons**

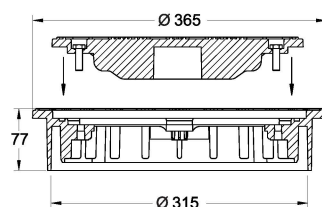

DTK315

## Telescopic covers

Square telescopic cover with full lid (without telescopic pipe)

increased resistance to **3 tons**

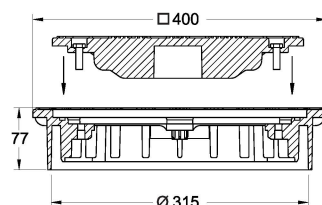

DTK315D

## Telescopic covers

Square telescopic cover with slotted lid (without telescopic pipe)

increased resistance to **3 tons**

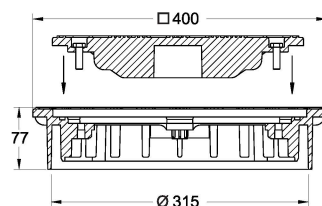

INCREASED RESISTANCE - CONTAIN UV STABILIZERS

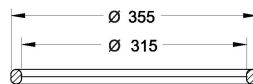

G70

**Gasket reducer**  
for corrugated pipe  $\varnothing 315$  (355)

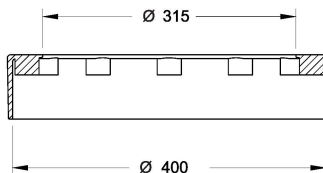

G71

**Gasket reducer**  
for solid wall pipe  $\varnothing 400$  /  $\varnothing 315$

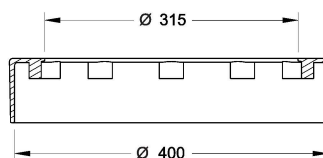

G72

**Gasket reducer**  
for corrugated pipe  $\varnothing 400$  /  $\varnothing 315$

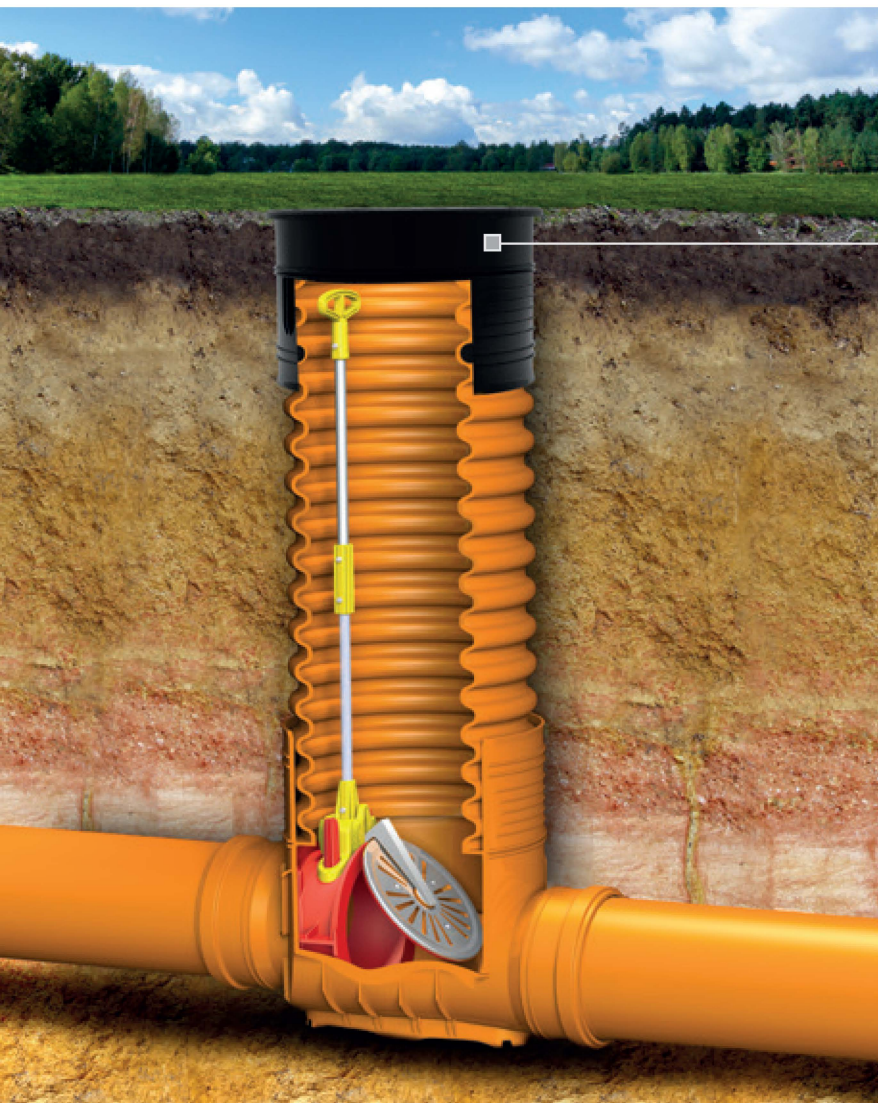

Watertight KARMAT cover

The application of watertight covers effectively prevents the returning sewage from spilling over the ground surface. They also block bad odours from escaping into the air.

# Possible chamber configuration and covers for $\varnothing$ 315 wells



PS315  
Watertight cover  
Full lid

PS315D  
Socket cover  
with stormwater lid

P315  
Standard cover

DTO315  
Round telescopic cover

DTK315  
Square telescopic cover



Solid wall riser pipe  $\varnothing$  315

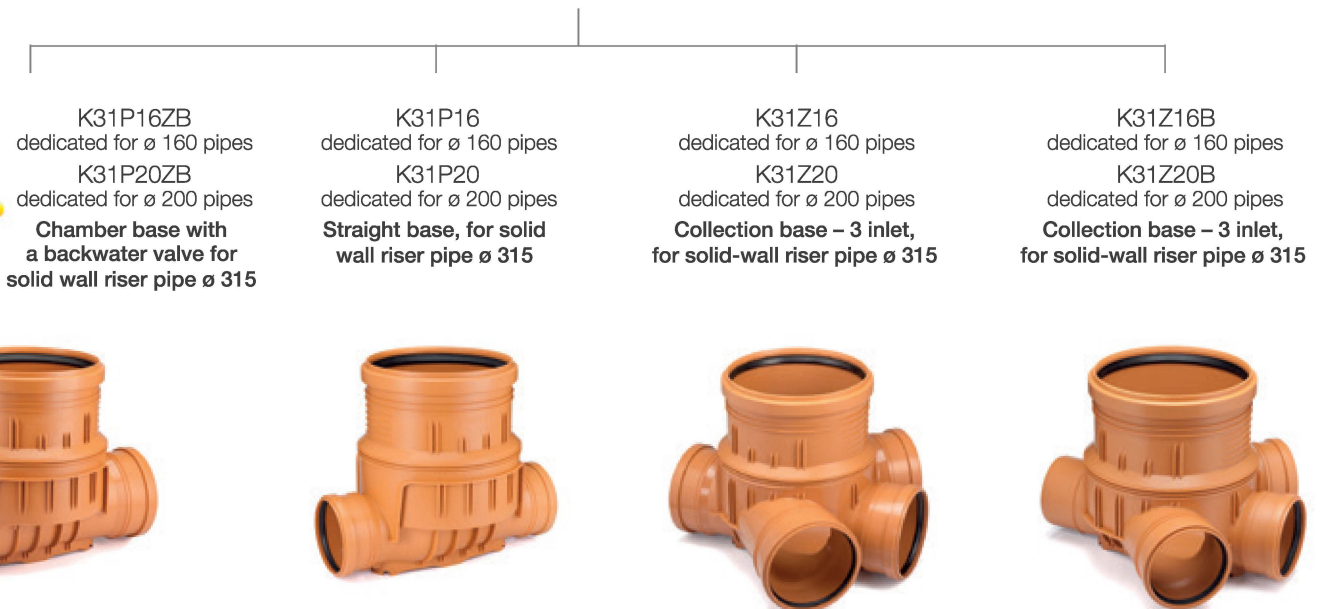

K31P16ZB  
dedicated for  $\varnothing$  160 pipes  
K31P20ZB  
dedicated for  $\varnothing$  200 pipes  
**Chamber base with  
a backwater valve for  
solid wall riser pipe  $\varnothing$  315**

K31P16  
dedicated for  $\varnothing$  160 pipes  
K31P20  
dedicated for  $\varnothing$  200 pipes  
**Straight base, for solid  
wall riser pipe  $\varnothing$  315**

K31Z16  
dedicated for  $\varnothing$  160 pipes  
K31Z20  
dedicated for  $\varnothing$  200 pipes  
**Collection base – 3 inlet,  
for solid-wall riser pipe  $\varnothing$  315**

K31Z16B  
dedicated for  $\varnothing$  160 pipes  
K31Z20B  
dedicated for  $\varnothing$  200 pipes  
**Collection base – 3 inlet,  
for solid-wall riser pipe  $\varnothing$  315**

# Possible chamber configuration and covers

## for $\varnothing$ 355 wells



PTO315      PTO315D      PTK315      PTK315D      PS355      PS355D      P355  
 Telescopic cover      Watertight cover Full lid      Socket cover with stormwater lid      Standard cover



G70  
 Seal for corrugated riser pipe



corrugated riser pipe  $\varnothing$  315  
 (external diameter  $\varnothing$  355 mm)

K35P16ZB dedicated for  $\varnothing$  160 pipes  
 K35P20ZB dedicated for  $\varnothing$  200 pipes  
**The chamber base with a backwater valve for corrugated riser pipe  $\varnothing$  315 (external diameter of riser pipe  $\varnothing$  355)**  
 K35P16 dedicated for  $\varnothing$  160 pipes  
 K35P20 dedicated for  $\varnothing$  200 pipes  
**Straight base, for corrugated riser pipe  $\varnothing$  315 (external diameter of riser pipe  $\varnothing$  355)**  
 K35Z16 dedicated for  $\varnothing$  160 pipes  
 K35Z20 dedicated for  $\varnothing$  200 pipes  
**Collection base – 3 inlet, for corrugated riser pipe  $\varnothing$  315 (external diameter of riser pipe  $\varnothing$  355)**  
 K35Z16B dedicated for  $\varnothing$  160  
 K35Z20B dedicated for  $\varnothing$  200  
**Collection base – 3 inlet, for corrugated riser pipe  $\varnothing$  315 (external diameter of riser pipe  $\varnothing$  355)**



# Possible chamber configuration and covers for $\varnothing$ 400 wells



PTO315

PTO315D

Telescopic cover

PTK315

PTK315D

PS400  
Watertight cover  
Full lid

PS400D  
Socket cover with  
stormwater lid

P400  
Standard cover



G71  
Gasket reducer

Solid wall riser pipe  $\varnothing$  400



Corrugated riser pipe  $\varnothing$  400



K40P16ZB  
dedicated for  $\varnothing$  160 pipes  
K40P20ZB  
dedicated for  $\varnothing$  200 pipes  
**The chamber base with  
a backwater valve for  
solid wall riser pipe  $\varnothing$  400**

K40P16  
dedicated for  $\varnothing$  160 pipes  
K40P20  
dedicated for  $\varnothing$  200 pipes  
**Straight base, for solid  
wall riser pipe  $\varnothing$  400**

K40Z16  
dedicated for  $\varnothing$  160 pipes  
K40Z20  
dedicated for  $\varnothing$  200 pipes  
**Straight base, for solid  
wall riser pipe  $\varnothing$  400**

K40Z16B  
dedicated for  $\varnothing$  160 pipes  
K40Z20B  
dedicated for  $\varnothing$  200 pipes  
**Straight base, for solid  
wall riser pipe  $\varnothing$  400**



# Universal system of connectors for drainage pipes

Produced and patented by the Karmat company is a versatile system of connectors for drainage pipes which serve to connect drainage pipes of variable diameter from 72 to 100 mm.

- quick and easy installation without the need for cutting holes in the pipes
- installation without the requirement of any specialistic tools
- resistant to harmful chemical compounds found in plant protective products
- solid and secure connection confirmed in tests
- safety for the natural environment - produced from polypropylene

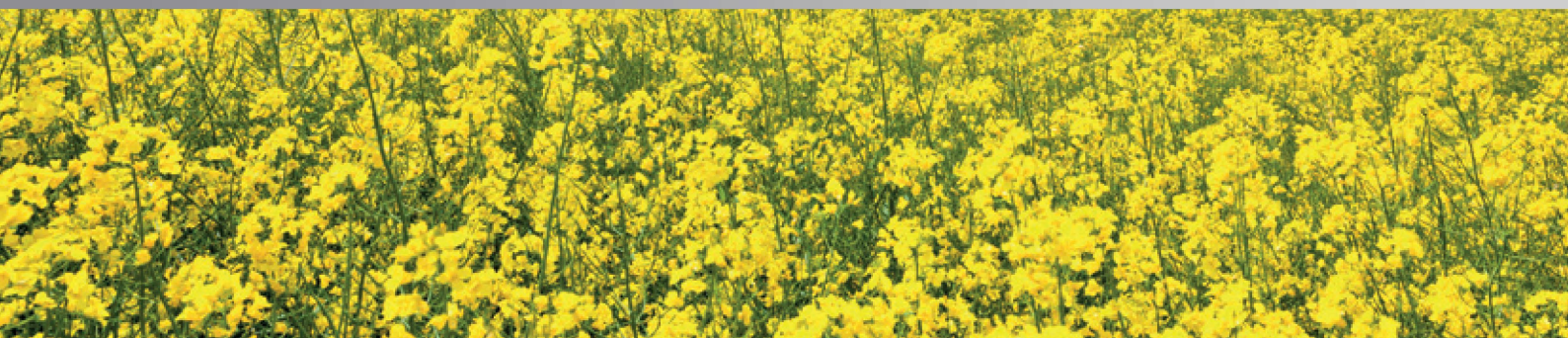
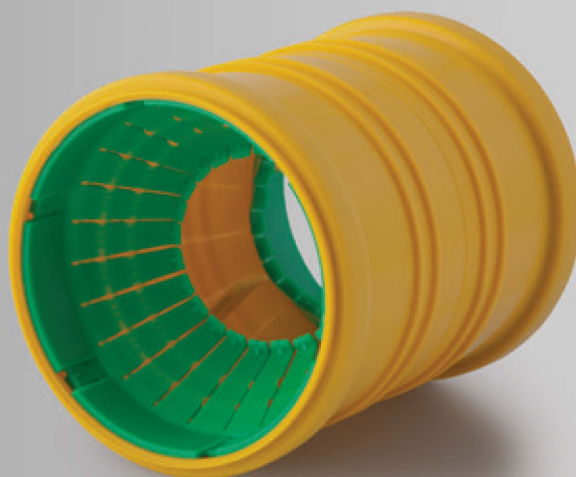

## Common applications



**KDR 14**  
**triple drainage junction**  
connects  $\varnothing$  72 -  $\varnothing$  100 mm drainage pipes



**KDR 10**  
**universal drainage coupler**  
connects  $\varnothing$  72 -  $\varnothing$  100 mm drainage pipes

TECHNICAL ACCEPTANCE CERTIFICATE ITB AT-15-9346/2014

# Common applications



**KDR 13**  
**universal drainage connector**  
connects  $\varnothing$  72 -  $\varnothing$  100 mm drainage pipes  
with  $\varnothing$  110 mm sewage pipe socket or collection well



**KDR 28**  
**90° universal drainage elbow**  
connects  $\varnothing$  72 -  $\varnothing$  100 mm drainage pipes



**KDR 11**  
**drainage pipe cap**  
sizes from  $\varnothing$  72 -  $\varnothing$  100 mm



**KDR 12**  
**universal external drainage connector**  
connects  $\varnothing$  72 -  $\varnothing$  100 mm drainage pipes  
with a plain end of  $\varnothing$  110 mm sewage pipe

# Specific applications



**KDR 26**  
**triple drainage junction**  
with  $\varnothing$  110 side connector  
connects  $\varnothing$  72 -  $\varnothing$  100 mm  
drainage pipes



**KDR 27**  
**triple drainage junction**  
with  $\varnothing$  110 connector  
connects  $\varnothing$  72 -  $\varnothing$  100 mm  
drainage pipes

**LATEST PRODUCT**



**KDR 23**  
**triple corner drainage junction**  
connects  $\varnothing$  72 -  $\varnothing$  100 mm  
drainage pipes



**KDR 24**  
**triple corner drainage junction**  
connects  $\varnothing$  72 -  $\varnothing$  100 mm  
drainage pipe



**KDR 30**  
**universal drainage**  
**inspection chamber**  
with riser pipe  $\varnothing$  110x500  
connecting drainage pipes  
 $\varnothing$  72 to  $\varnothing$  100  
aiding in the control of sediment  
buildup

# ø 50 Drainage pipe connectors



**KDR 17**  
ø 50 drainage pipe cap  
only ø 50 mm



**KDR 15**  
ø 50 triple drainage junction  
connects ø 50 mm drainage pipes



**KDR 16**  
ø 50 drainage coupler  
connects ø 50 mm drainage pipes



**KDR 21**  
ø 50 / ø 100 drainage coupler  
connects ø 50 mm drainage pipes  
with ø 72 - ø 100 mm drainage pipes

## Method of drainage installations for buildings



System installation is based on cutting a drainage pipe and inserting it into a coupler until it clicks. Lubrication of connected elements is unnecessary.

One of the greatest advantages of these connectors is the possibility to connect pipes from all producers by means of one system. Change of a supplier does not require the change of connectors. The system is equipped with elements enabling connection of drainage pipes of different diameters by means of one connector and also connecting them to collecting wells. The system possesses Technical Approval.

# Sample use of drainage couplers

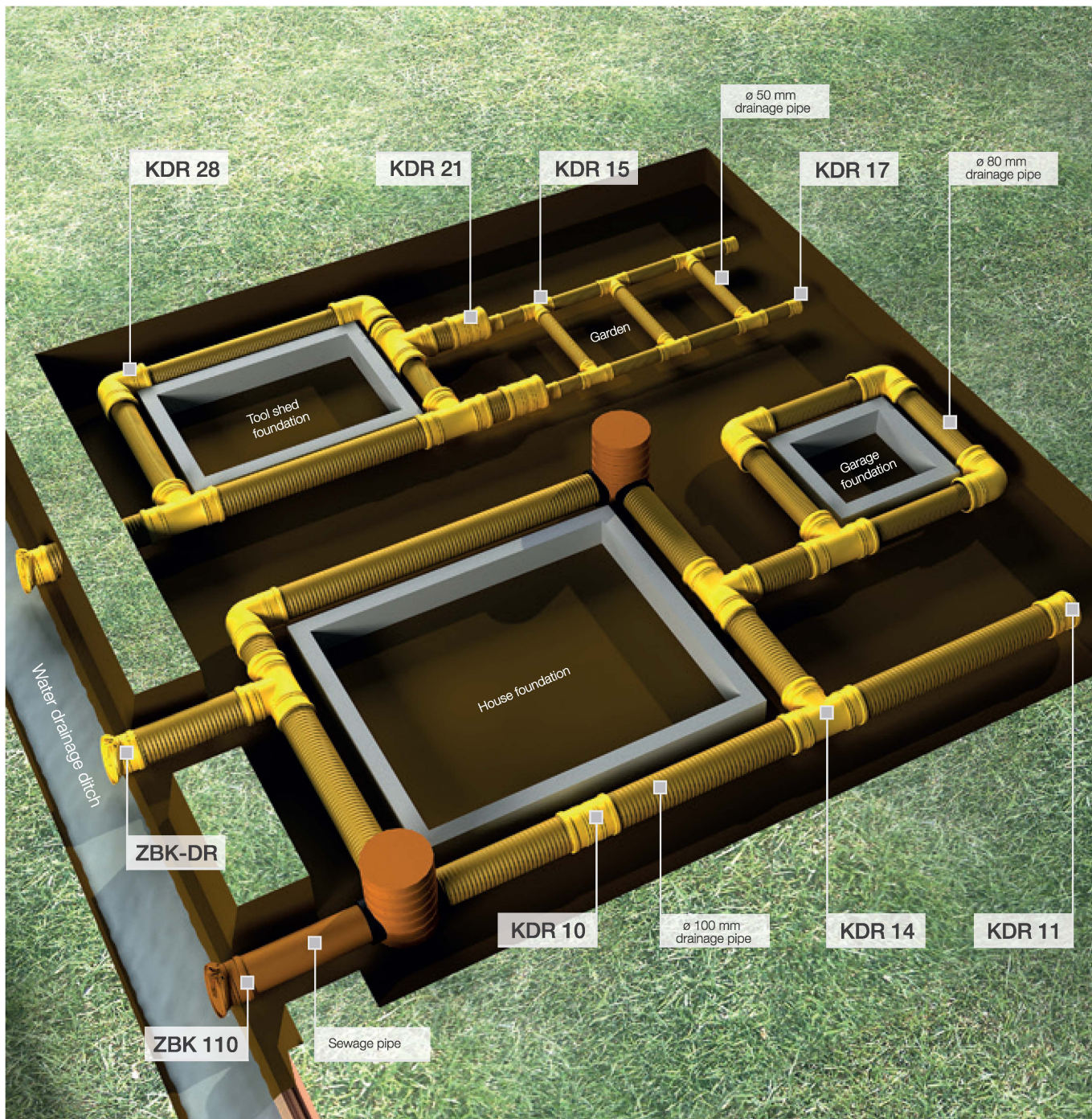

## Drainage Flap valve

- Installation of a flap valve on the waste water pipe leading to a drainage ditch or river prevents drainage installation from reverse flooding and silting up of installation when water level rises as a result of heavy rains.
- It prevents drainage pipes from blocking up caused by rats or other rodents.
- The construction of this device enables easy installation and provides durable and automatic operation.



**ZBK-DR**  
**Drainage Flap valve**  
 fits  $\varnothing 72 - \varnothing 100$  mm drainage pipes

Model ZBD-DR is restricted in the patent office

# Gutter flush system

Gutter drainage system is composed of elements that are linked together by means of a socket equipped with a lip seal. It's an ideal solution for multi-family houses, industrial buildings, public buildings and farm buildings. The elements are designed with great emphasis on the aesthetics of realization.

In perfect harmony with elevations of buildings of different styles. Depending on the roof surface we use parts with a diameter of 110 mm or 160 mm. The system produced by Karmat can be used with gutter systems from other manufacturers made from plastic or metal.

- increased resistance to fading
- resistance to corrosion, negative temperatures and chemicals
- materials: high quality polypropylene



The system guarantees tightness of connections at pressures up to 0.5 bar (about 5 m water column)

KARMAT gutter drainage system is made from highly durable polypropylene, resistant to weathering. Products made of polypropylene, do not corrode and do not deform under the influence of low and high temperatures. High quality material used for production is coloured and enriched with a UV stabilizer. This enables the system components to have an increased resistance against discoloration caused by sunlight. Complete gutter drainage system is a convenient solution during facade renovation.



Cleanouts with strainers are designed to protect underground storm sewer systems from leaves and other trash carried by water flowing down the gutters.

Thanks to the leaf-shaped strainers used in them, they effectively stop pollution, without obstruction to the water flow. They are also very easy to clean.

All rights of the design of the cleanouts with strainers have been reserved in the patent office.

# Cleanouts with strainer



**U6CBRS**  
Cleanout  $\varnothing$  160  
brown



**U6CORS**  
Cleanout  $\varnothing$  160  
orange



**U6CPS**  
Cleanout  $\varnothing$  160  
grey



**U6CGRS**  
Cleanout  $\varnothing$  160  
graphite



**U1CBRS**  
Cleanout  $\varnothing$  110  
brown



**U1CORS**  
Cleanout  $\varnothing$  110  
orange



**U1CPS**  
Cleanout  $\varnothing$  110  
grey



**U1CGRS**  
Cleanout  $\varnothing$  110  
graphite



# Reducers

Specially designed reducers allow you to connect components of different diameters.



U17ZBR  
Reducer  $\varnothing$  110/75  
brown



U61ZBR  
Reducer  $\varnothing$  160/110  
brown



U61ZOR  
Reducer  $\varnothing$  160/110  
orange



U61ZPO  
Reducer  $\varnothing$  160/110  
grey



U61ZGR  
Reducer  $\varnothing$  160/110  
graphite



RRWBR  
brown



RRWOR  
orange

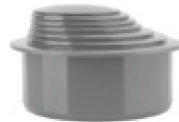

RRWPO  
grey



RRWGR  
graphite

**universal reducer**  
for gutter pipes  $\varnothing$  63/70/75/80/90/100 mm

## Universal gutter pipe reducer

Permits for an aesthetic connection of gutter pipes with sizes of: 63/70/75/80/90 or 100 mm to the  $\varnothing$  110 cleanout coupler or other connectors.



The universal coupler, just as other Karmat gutter system elements, is available in various colors with UV stabilizers which greatly increases resistance to discoloration due to atmospheric effects.



PLACE OF CUTTING →

$\varnothing$  63  
 $\varnothing$  70  
 $\varnothing$  75  
 $\varnothing$  80  
 $\varnothing$  90  
 $\varnothing$  100

Reduction rings have embossed leading grooves which allow for easy cutting by knife.

# Adapters

This kind of adapter allows you to connect a clean-out with commonly used drain pipes with diameters of 120 mm made from steel.



brown  
O1TPB  
adapter  $\varnothing$  110/124  
without seal

U1TPB  
adapter  $\varnothing$  110/124  
with seal



orange  
O1TPOR  
adapter  $\varnothing$  110/124  
without seal



grey  
O1TPUV  
adapter  $\varnothing$  110/124  
without seal



graphite  
O1TPGR  
adapter  $\varnothing$  110/124  
without seal



# T-connectors



brown

T-connector  $\varnothing$  110/110/45° U1TB4

T-connector  $\varnothing$  110/110/67° U1TB6

T-connector  $\varnothing$  110/110/90° U1TB9

# Elbows



U1KB3  
Elbow  $\varnothing$  110/30°  
brown



U1KB4  
Elbow  $\varnothing$  110/45°  
brown



U1KB6  
Elbow  $\varnothing$  110/67°  
brown



U1KB9  
Elbow  $\varnothing$  110/90°  
brown

# Coupler



# Cap



UZ11BR  
Coupler  $\varnothing$  110  
brown



01ZBR  
Cap  $\varnothing$  110  
brown

# Gutter Pipes



orange



U1KROR50  
 $\varnothing$  110 x 500

grey



U1KRPO50  
 $\varnothing$  110 x 500

graphite



U1KRGR50  
 $\varnothing$  110 x 500

brown



$\varnothing$  110 x 6000 U1RB6  
 $\varnothing$  110 x 4000 U1RB4  
 $\varnothing$  110 x 3000 U1RB3  
 $\varnothing$  110 x 2000 U1RB2  
 $\varnothing$  110 x 1000 U1RB1  
 $\varnothing$  110 x 500 U1KRB50  
 $\varnothing$  110 x 315 U1KRB35  
 $\varnothing$  110 x 250 U1KRB25



U6ROR-UV  
 $\varnothing$  160 x 500



U6RP-UV  
 $\varnothing$  160 x 500



U6RGR-UV  
 $\varnothing$  160 x 500



U6RBR-UV  
 $\varnothing$  160 x 500

# Storm water drainage system

If there is no possibility to drain storm water to a drainage system, an innovative simple and effective solution developed by Karmat is the overflow well. This installation drains water away from buildings (up to tens of meters away) and then it overflows it over the surface area. While redistributing water over the surface area it also simultaneously waters a selected area or part of a garden. The system continuously exudes remaining storm water into the ground which prevents the system from freezing over, thus drain pipes can run shallow beneath the ground surface.

## Easy installation

After digging or drilling a hole, put the overflow well into it at such a depth which will set the drain even with ground level. Fill the space around the draw pit with gravel of adequate granulation.

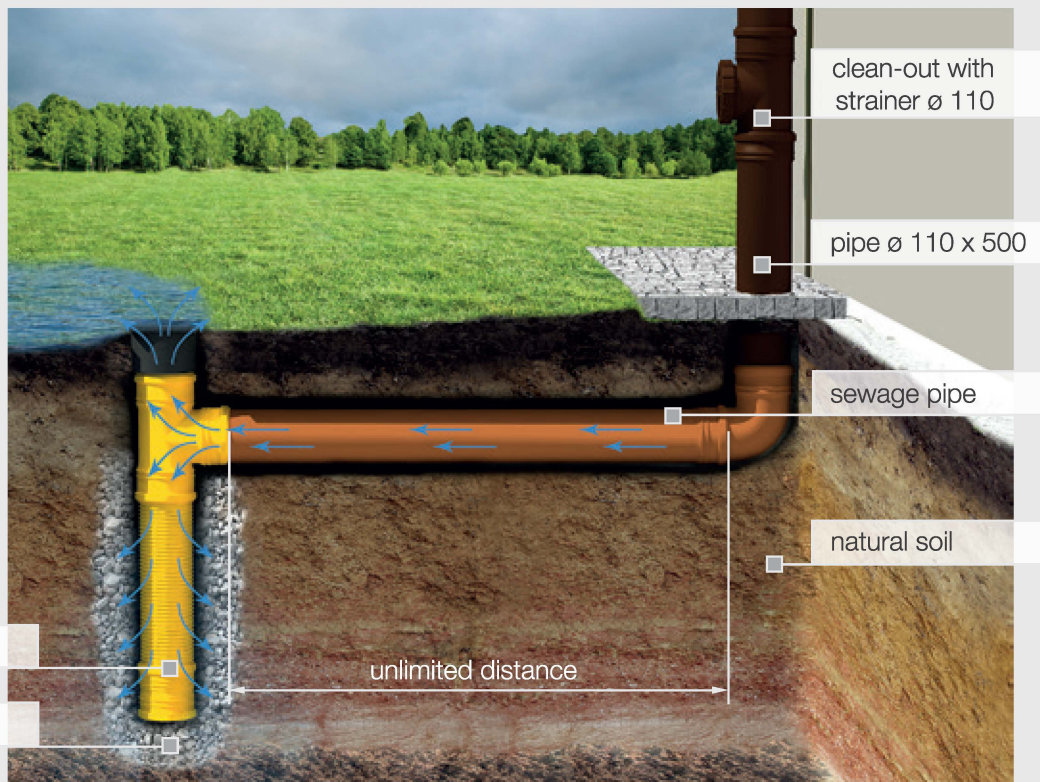

The main function of the system is to remove water away from the building and to redistribute it over the selected surface area



**SPR100**  
Overflow well  
ø 100



**SR100**  
Free standing  
exuder well ø 100

Free standing exuder well SR100 effectively eliminates, troublesome puddles formed on hardened surfaces after heavy rains.

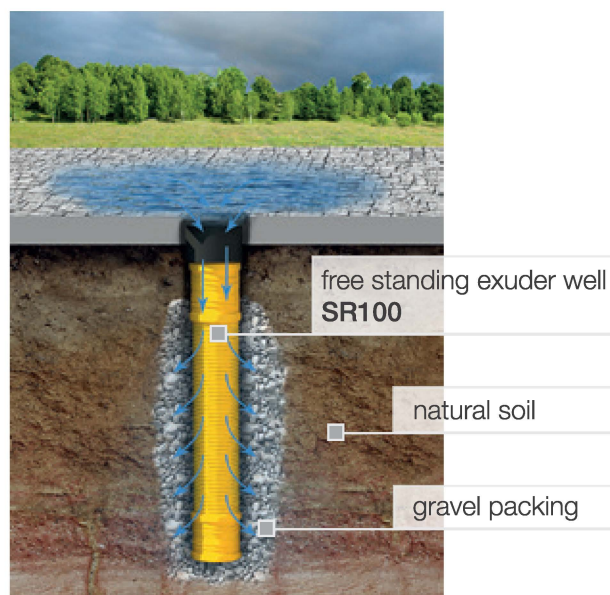

# Internal sewage drainage

.....

## Internal sewage drainage system – grey

It is produced with the greatest care for quality, which means that system components are easily and precisely assembled and the installation is tight and durable.

- material: high quality polypropylene
- resistant to corrosion and chemical compounds
- high aesthetics
- no need for maintenance
- infallible operation for many years



## Solid wall pipes

.....



### Solid wall pipe

- ø 110 x 750 mm U1R07
- ø 110 x 1000 mm U1R1
- ø 110 x 2000 mm U1R2
- ø 110 x 3000 mm U1R3
- ø 110 x 4000 mm U1R4
- ø 110 x 6000 mm U1R6



### Solid wall pipe

- ø 50 x 750 mm U5R07
- ø 50 x 1000 mm U5R1
- ø 50 x 2000 mm U5R2
- ø 50 x 3000 mm U5R3
- ø 50 x 4000 mm U5R4

# Short Pipes (stubs)

.....

# Deep socket stubs

.....

Stubs with deep socket enable modernization and extension of the sanitary installation and they are also helpful during repairs.



### Stubs

- ø 110 x 115 mm U1KR11
- ø 110 x 250 mm U1KR25
- ø 110 x 315 mm U1KR35
- ø 110 x 500 mm U1KR50

### Stubs

- ø 50 x 250 mm U5KR25
- ø 50 x 315 mm U5KR35
- ø 50 x 500 mm U5KR50

### Deep socket stubs

- ø 110 x 250 mm U1KRM

### Deep socket stubs

- ø 50 x 250 mm U5KRM

# Elbows

.....



U1K1

Elbow ø 110/15°



U1K3

Elbow ø 110/30°



U1K4

Elbow ø 110/45°



U1K6

Elbow ø 110/67°



U1K9

Elbow ø 110/90°



U5K1

Elbow ø 50/15°



U5K3

Elbow ø 50/30°



U5K4

Elbow ø 50/45°



U5K6

Elbow ø 50/67°



U5K9

Elbow ø 50/90°

# T-connectors

.....



U1T4

T-connector  $\varnothing$  110/110/45°



U1T6

T-connector  $\varnothing$  110/110/67°



U1T9

T-connector  $\varnothing$  110/110/90°



U15T4

T-connector  $\varnothing$  110/50/45°



U15T6

T-connector  $\varnothing$  110/50/67°



U15T9

T-connector  $\varnothing$  110/50/90°



U5T4

T-connector  $\varnothing$  50/50/45°



U5T6

T-connector  $\varnothing$  50/50/67°



U5T9

T-connector  $\varnothing$  50/50/90°

## Couplers

.....



UZ11

Coupler  $\varnothing$  110



UZ55

Coupler  $\varnothing$  50



UZ11N

Joining sleeve  $\varnothing$  110



UZ55N

Joining sleeve  $\varnothing$  50

## Joining sleeves

.....

# Reducers

.....



U15Z  
Reducer  $\varnothing$  110/50



U1TP  
Adapter  $\varnothing$  110/124  
with seal

O1TP  
Adapter  $\varnothing$  110/124  
without seals



U5TP  
Adapter  $\varnothing$  50/72  
with seal

O5TP  
Adapter  $\varnothing$  50/72  
without seals

# Caps

.....



O1Z  
Cap  $\varnothing$  110



O5Z  
Cap  $\varnothing$  50



O1UP  
Grip  $\varnothing$  110



O5UP  
Grip  $\varnothing$  50

Innovative grips with a hinge for easier installation

# T-connections with three sockets

.....



U1T3K

T-connections with three sockets  $\varnothing$  110/110/110/90°



U5T3K

T-connections with three sockets  $\varnothing$  50/50/50/90°

# Cleanouts



# Cross connections



U1C  
Cleanout  
ø 110



U5C  
Cleanout  
ø 50



U11CZ  
Cross  
connections  
ø 110/110/110/90°



U15CZ  
Cross  
connections  
ø 110/50/50/90°



U55CZ  
Cross  
connections  
ø 50/50/50/90°

## Sample installation



We recommend using ready-made lubricants available in shops. You should not use any petroleum based lubricants such as grease or oils.



Assembly is carried out by connecting the socket of the connector or a pipe, equipped with a rubber gasket, with a bare end of any component.

When using Karmat internal sewage system service and maintenance is unnecessary. Once installed they work reliably for many years.



# Internal sewage drainage – white

.....

## Internal sewage drainage system – white

Components of the internal sewage system, in white colour are intended for installation in places of higher esthetical requirements.

- Material: high quality polypropylene
- Resistant to corrosion and chemicals
- High aesthetics



## Solid wall pipes

.....

## Deep socket stubs

.....



### Solid wall pipe

Ø 50 x 1000 mm B5R1

Ø 50 x 2000 mm B5R2

### Solid wall pipe

Ø 32 x 1000 mm B3R1

Ø 32 x 2000 mm B3R2

### Deep socket stub

Ø 110 x 250 mm B1KRM

### Deep socket stub

Ø 50 x 250 mm B5KRM

# Short Pipes (stubs)

.....



**Stub**  
ø 110 B1WC



**Stub**  
ø 110 x 250 mm B1KR25  
ø 110 x 315 mm B1KR35  
ø 110 x 500 mm B1KR50



**Stub**  
ø 50 x 250 mm B5KR25  
ø 50 x 500 mm B5KR50



**Stub**  
ø 32 x 250 mm U3KR25  
ø 32 x 500 mm U3KR50

# Elbows

.....



**B1K3**  
Elbow ø 110/30°



**B1K4**  
Elbow ø 110/45°



**B1K6**  
Elbow ø 110/67°



**B1K9**  
Elbow ø 110/90°



**B5K4**  
Elbow  $\varnothing$  50/45°



**B5K6**  
Elbow  $\varnothing$  50/67°



**B5K9**  
Elbow  $\varnothing$  50/90°



**G35**  
Elbow  $\varnothing$  32/15°



**G36**  
Elbow  $\varnothing$  32/30°



**U3K4**  
Elbow  $\varnothing$  32/45°



**U3K6**  
Elbow  $\varnothing$  32/67°



**U3K9**  
Elbow  $\varnothing$  32/90°

## Reducers

.....



**U53ZW**  
Internal reducer  
 $\varnothing$  50/32



**U53Z**  
Reducer  
 $\varnothing$  50/32



**U539Z**  
Reducing bend  
 $\varnothing$  50/32/90°

## Caps

.....



**B1Z**  
Cap  $\varnothing$  110



**B5Z**  
Cap  $\varnothing$  50



**G43**  
Cap  $\varnothing$  32

# Floor-drains

Floor drains are used to drain household and industrial sewage as well as rainwater. Their construction enables assembly on the ground level, floor and roof levels. They are a final point in gravitational sewage systems. Unlike other manufacturers' products the casing of our floor drains is tightly welded, which prevents the reentry of undesirable odours.

- Resistant to warping
- The grate possesses an inspection cap with a seal which allows entry for a drain auger
- The housing is tightly welded to the syphon
- Resistant to above standardized pressure and impacts of heavy objects
- Material: high quality polypropylene
- Durable and resistant to corrosion, chemicals and temperatures of up to 95°C



50B-1B  
Floor-drain ø 50



50C-1B  
Floor-drain ø 50



50C-1C  
Floor-drain ø 50



50B-2B  
Floor-drain ø 50



50C-2B  
Floor-drain ø 50



50C-2C  
Floor-drain ø 50

# Installation method of floor drain

Floor drain installation does not necessarily have to be made by a professional, but the height of the grates should be measured exactly, taking into consideration the level of the tiles laid on the floor.

The casing should be placed in concrete, which increases its durability and reliability of long-term operation. The special design of the rim enables easy and precise enclosure of the floor drain grate with tiles.

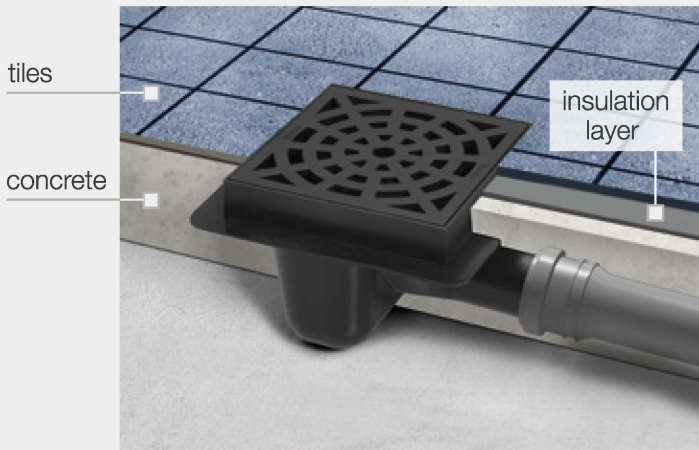

Easy sewage pipe access for maintenance. The inspection cap is equipped with a seal.

**LATEST PRODUCTS**

## Mini inspection chambers

Convenient installation site to hide and protect water valves as well as electric connections in gardening systems.

Example of instalation



- Used as an inspection point of underground water reservoirs, infiltrator and wastewater treatment chambers.
- Used as an inspection point of drainage pipes aiding in the control of sediment build up.
- Used as an additional access point to pipelines in order to clean out blockages.
- Telescopic construction eases fitment to the ground level.



MSN 40

Mini inspection chamber short (40 cm)



MSN 80

Mini inspection chamber high (80 cm)



MT 125

Telescopic pipe  $\varnothing$  125 for mini inspection chamber



MST 125

Mini inspection chamber with telescopic pipe  $\varnothing$  125

# ABOUT US



Karmat is a long-running family tradition. In the year 1932, the first family business was established which was a foundry producing various color metals and metal products. Since then, the tradition of developing and modernizing the manufacture from generation to generation grew. In 1978 it was one of the first privately-owned companies which started producing polymer-based products.

Keeping to what became a family tradition, in 1985 Karmat Works was established.

The hard work and drive led to the construction of a new modern facility which, in January 2016, became our new headquarters.

A sizable, complacent production hall, state-of-the-art machinery and infrastructure help to uphold impeccable quality. Capacious warehouse and a modern storage system guarantees comfortable access to all of our products by our customers at any time, even during peak seasons.

Presently, we are a leading producer of anti-flood devices.

We offer inexhaustible knowledge on their use and application. We constructed innumerable solutions known and appreciated by many in their day to day lives. We are looking forward to cooperating with you.

Grzegorz Bąk

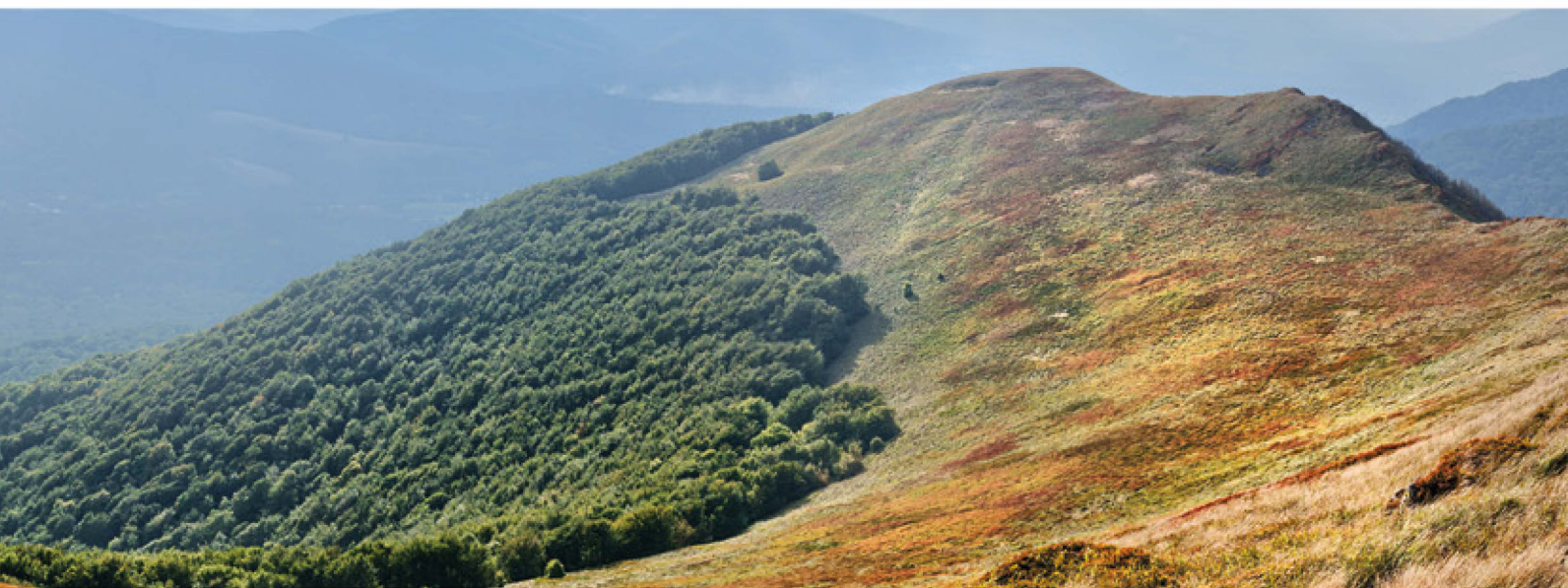

**Sanitary System Production Company**

36-072 Świlcza 147c, Poland  
tel. +48 17/ 85 60 376, Tel./fax +48 17/ 85 13 141  
[www.BackWaterValve.eu](http://www.BackWaterValve.eu)